

Operating instructions

Shut-off valves



Read the instructions prior to performing any task!

Stahl-Armaturen PERSTA GmbH
Mülheimer Str. 18
59581 Warstein-Belecke, Germany
Telephone: +49 2902 762-02
Fax: +49 2902 767-03
Email: info@persta.de
Internet: www.persta.com
Translation of the original operating instructions
Dok.-Nr. 6419.DE.STD.08.2016, 2, en_GB

Information about the operating instructions

These instructions enable the safe and efficient handling of the valve.

These instructions are an integral part of the valve and must be kept in the vicinity of the valve so that they are available to the personnel at all times.

The personnel must have carefully read and understood these instructions before commencing any work. The basic prerequisite for safe work is compliance with all the specified safety and handling instructions.

Furthermore, the local occupational safety regulations and general safety requirements must be complied with for the area in which the valve is used.

The figures in these instructions are provided as examples only and may deviate from the actual version.



Although the size and pressure ratings of the valve types vary, the information in these instructions applies generally to all valves, provided nothing to the contrary is specified.

Scope of the document

These instructions apply to the following versions of the shut-off valves:

Designation	Series	Nominal diameter (DN) [mm]	Pressure rate	Class*
Shut-off valve	200 AE/BE/AJ/BJ	10–250	PN 10–160	900
Shut-off valve	200 AL	15–200	PN 10–160	900
Shut-off valve	200 AB/BB/AF/BF	6–15	PN 640	-
Shut-off valve	270 BF/KF/VF	6–25	PN 640	-
Shuttle valve	203 EH/EM/EM/FM	10–250	PN 10–160	-

* Assignment number in the pipe construction

Other applicable documents

- Ignition hazard assessment GA004
- Connection diagram provided
- Risk analysis according to Pressure Equipment Directive
- Risk analysis according to Machinery Directive
- Actuator instructions
- Technical data sheet
- Bolt tightening torques according to the website: www.persta.com
- And other documents included in the delivery

Customer Service - Stahl-Arma- turen PERSTA GmbH

Mülheimer Str. 18
59581 Warstein-Belecke
Germany
Phone: +49 2902 762-900
Fax: +49 2902 767-03
e-mail: info@persta.de

Revision overview

Revision number	Change/Supplemented information	Date
1	Updates to chapter " <i>Intended use</i> ".	05/05/2021

Table of contents

1	Overview	7
2	Safety	11
	2.1 Symbols in this manual.....	11
	2.2 Intended use.....	13
	2.3 Safety signs.....	14
	2.4 Safety devices.....	16
	2.5 Residual risks.....	17
	2.5.1 Basic dangers at the workplace.....	17
	2.5.2 Electric shock hazard.....	18
	2.5.3 Danger due to hydraulics.....	18
	2.5.4 Hazards associated with the pneumatic system.....	19
	2.5.5 Mechanical hazards.....	19
	2.5.6 Thermal dangers.....	20
	2.5.7 Danger due to hazardous substances and operating materials.....	20
	2.6 Behaviour in the event of an emergency.....	22
	2.7 Responsibility of the operating company.....	22
	2.8 Personnel requirements.....	23
	2.9 Personal protective equipment.....	26
	2.10 Spare parts.....	27
	2.11 Environmental protection.....	28
3	Functional description	29
	3.1 Operating principle of the shut-off valve.....	29
	3.2 Versions of the shut-off valve.....	30
	3.2.1 External seal.....	30
	3.2.2 Shut-off element.....	32
	3.2.3 Actuator variants.....	32
	3.2.4 Body shape.....	34
	3.2.5 Display elements.....	37
	3.3 Connections.....	38
4	Transport and storage	41
	4.1 Safety instructions for transport and storage.....	41
	4.2 Transport of packages.....	42
	4.3 Storage of the valve.....	43
	4.4 Storage of spare parts.....	43
5	Installation	45
	5.1 Safety instructions for installation.....	45
	5.2 Before the installation.....	47
	5.3 Installing the valve.....	47
	5.4 For electric actuators, connect the power supply.....	48
	5.5 For a hydraulic actuator, connecting the hydraulic system.....	49

5.6	For a pneumatic actuator, connecting the pneumatic system.....	49
5.7	After the installation.....	50
5.7.1	Pickling the valve.....	51
5.7.2	Painting the valve.....	51
5.7.3	Executing the system pressure test and leak test... ..	51
5.7.4	Applying thermal insulation.....	52
6	Initial start-up.....	53
6.1	Safety instructions for initial start-up.....	53
6.2	Before commissioning.....	56
6.3	Carrying out initial start-up.....	57
7	Operation.....	59
7.1	Safety instructions for operation.....	59
7.2	Operating the valve.....	61
7.3	Operating the valve in an emergency.....	62
8	Maintenance.....	65
8.1	Safety instructions for maintenance.....	65
8.2	Maintenance schedule.....	70
8.3	Maintenance tasks.....	71
8.3.1	Visually checking the valve.....	71
8.3.2	Lubricating moving parts (stem thread).....	72
8.3.3	Replace the gland packing.....	73
8.3.4	Removing and checking the stem.....	85
8.4	After maintenance.....	86
9	Faults and troubleshooting.....	87
9.1	Safety notices for fault correction.....	87
9.2	Fault table.....	90
10	Removal, disposal.....	93
10.1	Safety notice for dismantling and disposal.....	93
10.2	Removal.....	96
10.3	Disposal.....	97
11	Technical data.....	99
12	Index.....	101

1 Overview

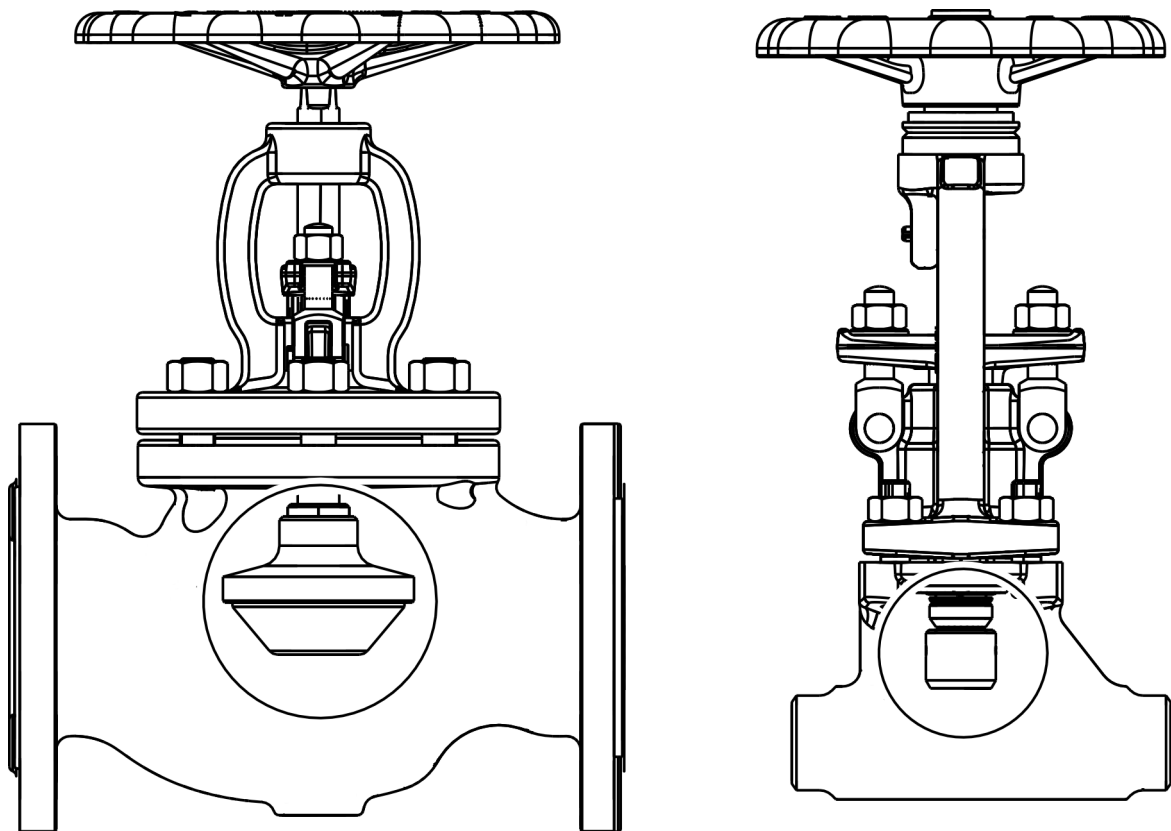

Fig. 1: Shut-off valves with different shut-off elements

Shut-off valve

The valve referred to as shut-off valve was designed for installation in pipes.

Depending on the version of the shut-off valve, shut-off or regulation of the pipeline medium flowing through the valve is possible.

The body of the valve is flanged, bolted or welded into the pipe, depending on the version.

In the closed position, the shut-off element (Fig. 1/sectional views) prevents the pipeline medium from flowing through the valve.

If the shut-off valve is used for regulation, the flow of the pipeline medium is influenced by the position of the shut-off element.

Actuators

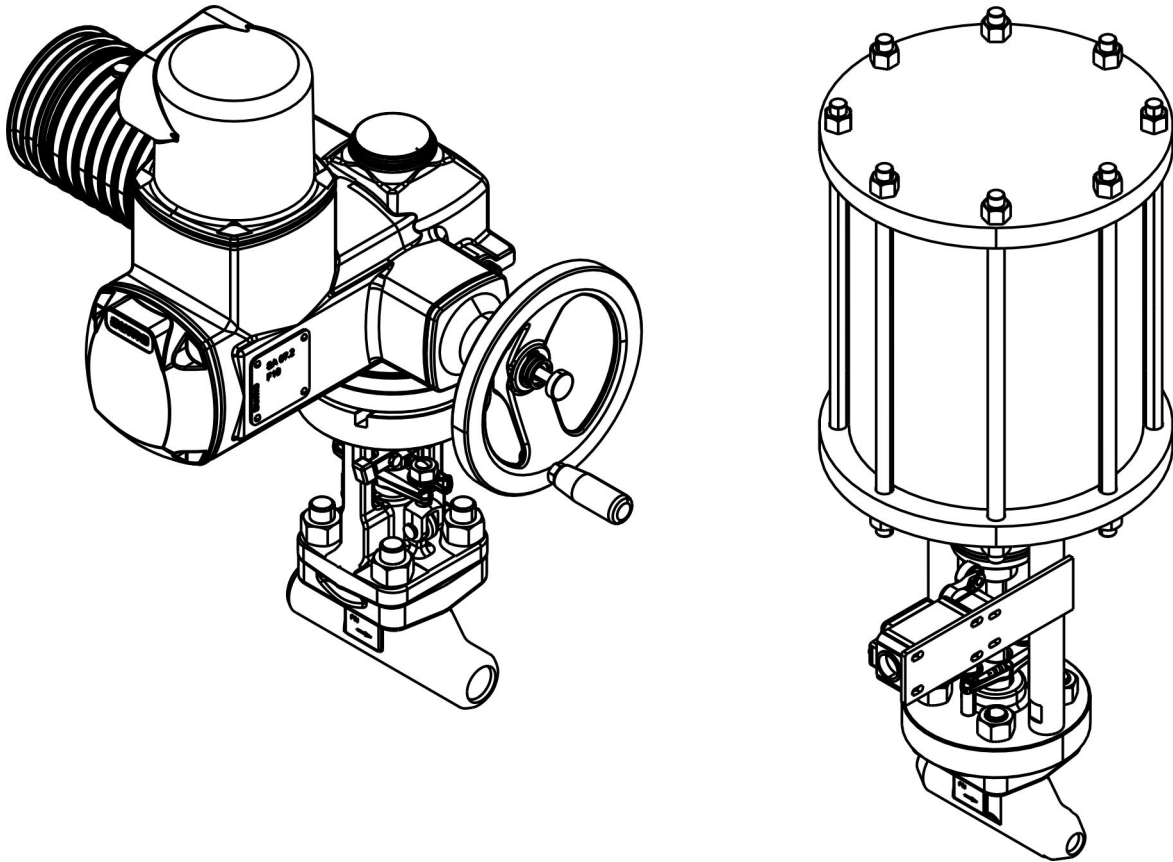

Fig. 2: Optional actuators

The shut-off element is moved in or out via the stem. Depending on the version, the stem is operated manually via a handwheel attached to the bonnet, electrically (Fig. 2/left), hydraulically or pneumatically (Fig. 2/right).

Body shapes

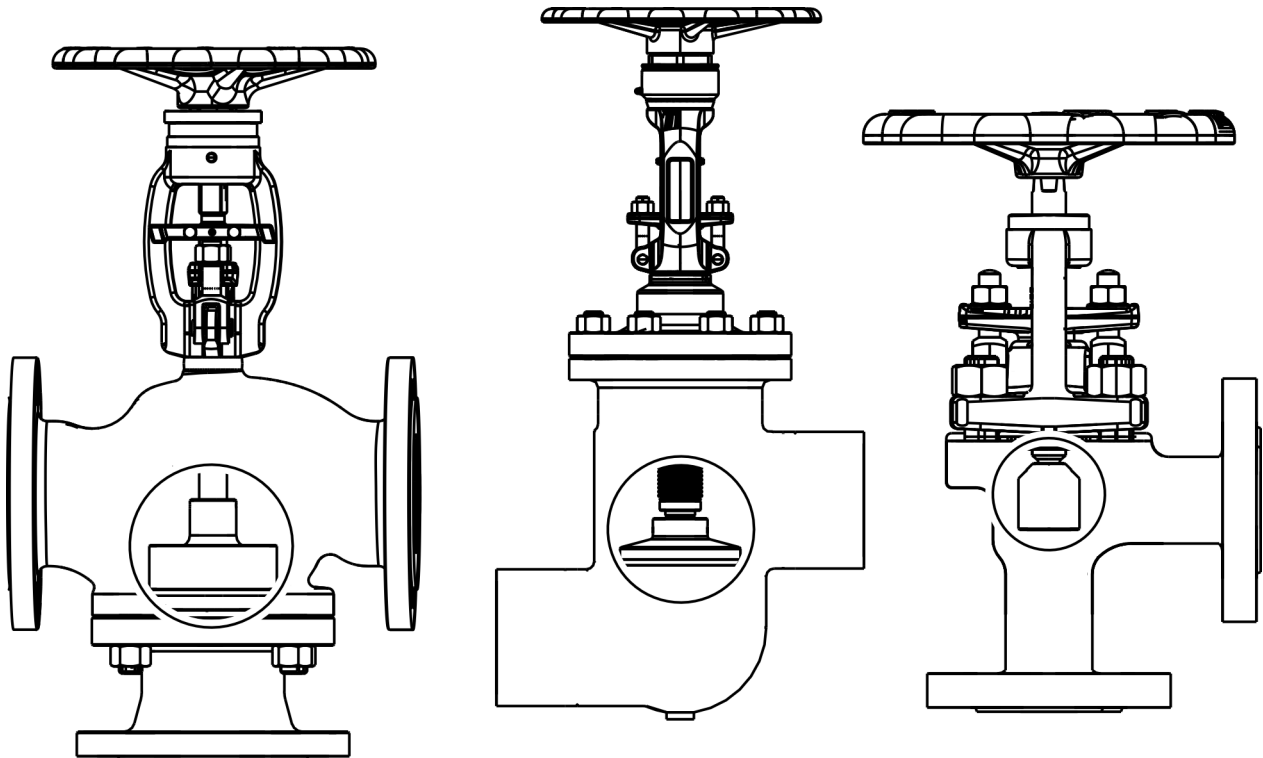

Fig. 3: Different body shapes

In addition to the T-pattern (inlet and outlet sides on one horizontal axis), further body shapes are possible (Fig. 3).

- Shuttle valve (☞ “Shuttle valve” on page 36)
- Z shape (☞ “Z shape” on page 37)
- Angle pattern valve ☞ “Angle pattern valve” on page 35)

Tools

The following tools are required for the tasks described in the operating instructions:

Forklift

Forklift with sufficient load-bearing capacity for transport of valves.

Hoist

Hoist with sufficient load-bearing capacity for transporting valves and components.

Hook wrench

Hand tool for activating the threaded bush or mounted electric actuator.

Knock-out tool

Pin-like tool for driving the tension pin out of the stem.

Sling gear

Functional and approved gear for attaching valves and components on the hoist.

Spacers

Spacers for use during the separation of bonnet and body.

2 Safety

2.1 Symbols in this manual

Safety instructions

Safety instructions are indicated by symbols in this manual. The safety instructions are introduced by signal words that indicate the scope of the hazard.

**DANGER!**

This combination of symbol and signal word indicates a hazardous situation that, if not avoided, will result in death or serious injury.

**WARNING!**

This combination of symbol and signal word indicates a potentially hazardous situation that, if not avoided, may result in death or serious injury.

**CAUTION!**

This combination of symbol and signal word indicates a potentially hazardous situation that, if not avoided, may result in minor or moderate injury.

**NOTICE!**

This combination of symbol and signal word indicates a potentially hazardous situation that, if not avoided, may result in damage to property.

**ENVIRONMENT!**

This combination of symbol and signal word indicates potential hazards for the environment.

Safety instructions in specific instructions

Safety instructions may refer to specific, individual instructions. Such safety instructions are integrated into the specific instruction, so that the flow of reading is not interrupted during performance of the task. The signal words described above are used.

Example:

1.  Loosen the bolt.

2. 





CAUTION!
Risk of getting pinched by the cover!

Close the cover carefully.

3.  Tighten the bolt.

Special safety instructions

The following symbols are used in the safety instructions to indicate special hazards:

Warning signs	Type of danger
	Warning – high-voltage.
	Warning – danger zone.





Tips and recommendations



This symbol indicates useful tips and recommendations as well as information on efficient and trouble-free operation.

Additional symbols

The following symbols are used throughout this manual to highlight specific instructions, results, lists, references and other elements:

Symbol	Explanation
	Step-by-step instructions
	Results of actions
	References to sections of these operating instructions and other applicable documents
	Lists without a defined sequence

2.2 Intended use

Valves of the specified series are designed for installation in pipes under the following conditions:

- Valve with throttling valve cone: Normal operation of the valve as open/close valve. Brief operation of the valve as throttling valve with increased probability of wear.
- Valve with regulating cone: Operation of the valve for regulating the flow, up to completely open/closed.
- Installation in horizontal or vertical pipes.
- Maximum number of 1000 load cycles between a depressurized state and the maximum permissible pressure PS.
- Any number of load cycles at pressure fluctuations of up to 10 % of the maximum permissible pressure PS.
- Operation of the valve with liquid or gaseous media, without particular corrosive, chemical or abrasive impact.
- Temperature change speeds of maximum 6 K/min (6°C/min).
- Generally used flow rates depending on the type of medium and the application for which the valve is used.
- Operation of the valve without additional external influences, such as pipe forces, vibrations, wind loads, earthquakes, corrosive environments, fires, traffic loads, decomposition pressures of unstable fluids.
- Operation of the valve only within the limits specified on the rating plate (☞ *“Rating plate” on page 14*).
- If the valve is operated in the creep range, the valve is designed for a maximum operating time of 100,000 H. The valve must be replaced afterwards.
- No temperature increases were considered. In case of use in the hot vapour area, temperature increases must be considered according to the regulations of the operating company.
- The test pressure for a recurring test must not exceed the maximum permitted pressure PS multiplied by 1.3.
- The valve may only be operated if internal pressure loading is predominantly dormant. Additional loads (e.g. stationary thermal stress, unsteady pressure and temperature loads in case of alternating loads or pipe loads) were not considered.

Intended use includes compliance with all the information contained in this manual.

Any use that deviates from the intended use or any other form of use constitutes misuse.

Misuse



WARNING!

Danger in the event of misuse!

Misuse of the valve can cause dangerous situations.

- Do not use the valve as a throttling valve in normal operation.
- Connect the pipes so that they are free of tension.
- Pay attention to the correct installation position of the valve (☞ *Chapter 11 “Technical data” on page 99*).
- Do not use valves as an anchor point.
- Never operate the valve in installation positions other than those approved (☞ *Chapter 11 “Technical data” on page 99*).
- Never operate valves at temperatures near or below the freezing point of the pipeline medium.
- Do not exceed the number of permitted load cycles (☞ *Chapter 2.2 “Intended use” on page 13*).

2.3 Safety signs

The following symbols and instruction signs are in the work area. These symbols and instruction signs refer to the immediate vicinity in which they are affixed.



WARNING!

Danger if signs are illegible!

Over time, stickers and signs can become fouled or can become illegible in some other manner, so that dangers are not recognised and necessary operating instructions cannot be complied with. This results in a danger of injury.

- Keep all safety, warning, and operating instructions that are affixed to the device in legible condition.
- Replace damaged signs or stickers immediately.

Rating plate

The rating plate is on the valve. Depending on the version, the following information is on the rating plate:

- Confirmation number
- Article number
- Year of manufacture

- Nominal diameter
- Nominal pressure/design data

Flow direction arrow

Fig. 4: Flow direction arrow

The flow direction is indicated by an arrow on the valve (Fig. 4).

In the arrowed direction, medium flows against the shut-off element from below.

Position indicator (mechanical)

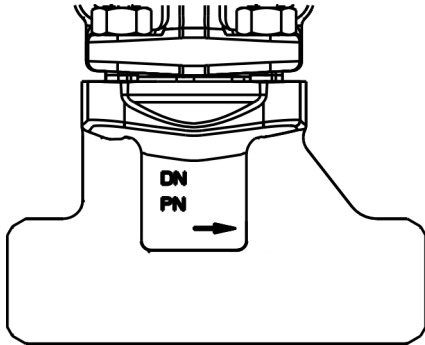
Fig. 5: Mechanical position indicator

The valve has a mechanical position indicator.

A crossbar (Fig. 5/1) is bolted on to the stem, guided along the bonnet. Depending on the position of the shut-off element in the body, the crossbar indicates the "Open" (crossbar in upper position) or "Shut" position (crossbar in lower position).

The crossbar also serves as an anti-twist device for the stem and as a shifting claw for optional actuators.

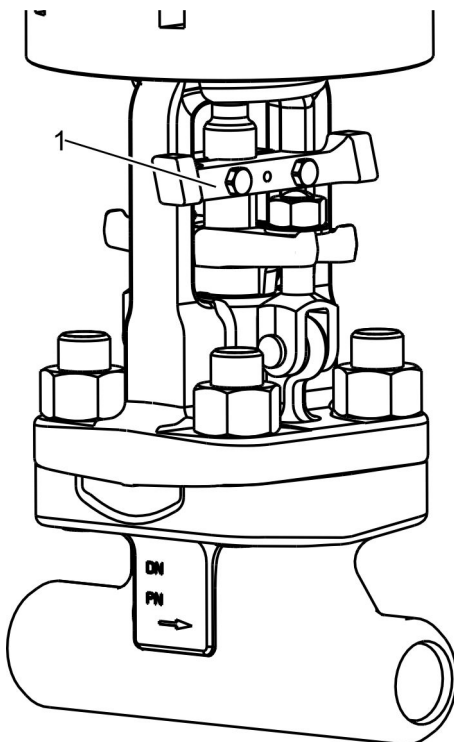
Opening direction / closing direction indication for manual actuator

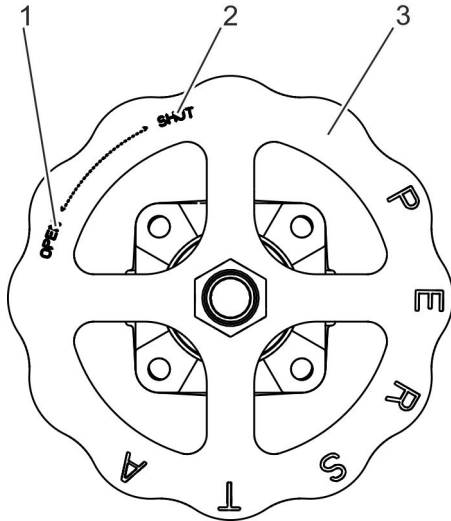

The (Fig. 6/3) the opening (Fig. 6/1) and closing direction (Fig. 6/2) are marked on the handwheel.

- Open
- Shut

Fig. 6: Opening direction and closing direction indication

Customer-specific markings

Additional markings (e.g. max. temperature limits) are available on customer request.

2.4 Safety devices

Torque switch

The closing of the valve with electric actuator is limited by a torque switch. At a permanently set torque, the actuator shuts down and the valve is closed.

Limit switch

The opening of the valve with electric actuator is limited by a limit switch. At a permanently set distance, the actuator shuts down and the valve is opened.

Emergency actuation of the electric actuator

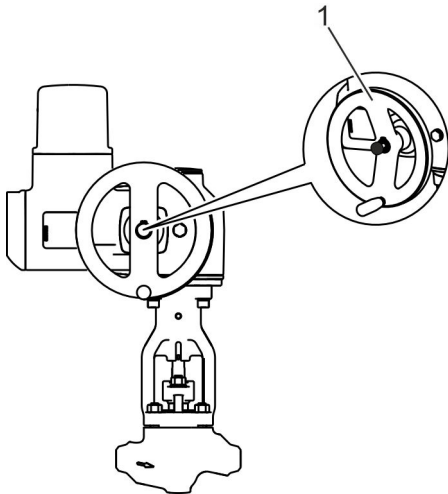

The electric actuator also has a handwheel (Fig. 7/1). If the actuator is defective or if the controller fails, the valve can be operated via the handwheel.

Fig. 7: Emergency actuation

2.5 Residual risks

The valve has been developed and manufactured to the state-of-the-art and in accordance with generally accepted rules of safety. Nevertheless residual risks remain that require careful handling. The residual risks and the resulting behaviours and measures are listed below.

2.5.1 Basic dangers at the workplace

Hazardous areas



DANGER!

Life-threatening danger due to failure to comply with the rules of behaviour specified for hazardous areas!

Depending on the version the valve can be used in hazardous areas. There is life-threatening danger if the rules of behaviour are not complied with within these areas.

- Ensure that tasks on the valve can be executed at the installation site.

Trip hazard



CAUTION!

Danger of injury due to tripping up!

There is a danger of fall injuries in the area of use of the valve.

- Install cable and connection lines in such a manner that there are no trip hazards.

2.5.2 Electric shock hazard

Electric shock



DANGER!

Risk of fatal injury from electric shock!

There is a risk of fatal injury when touching live components of the actuator. Switched-on electrical components can execute uncontrolled movements and can cause serious injuries.

- Prior to starting work, switch off the supply of electricity and definitively disconnect it.
- Only have an electrician perform tasks on electrical lines and components.

2.5.3 Danger due to hydraulics

Fluid under high pressure



WARNING!

Danger of injury due to hydraulic energy!

Hydraulically-powered components of the valve, as well as the triggering of the overpressure valve can cause severe injuries.

- Only have specialised personnel perform tasks on the hydraulic system.
- Prior to starting the tasks on the hydraulic system ensure that it is completely depressurised. Completely depressurise pressure accumulators.
- Operate the valve in a frost-free environment to prevent the body from bursting.
- Wear personal protective equipment.

2.5.4 Hazards associated with the pneumatic system

Hazards associated with the pneumatic system

**WARNING!****Danger of injury due to pneumatic energy!**

Pneumatically-powered components of the valve, can cause severe injuries.

- Only have pneumatic specialists perform tasks on the pneumatic equipment.
- Prior to starting the tasks on the pneumatic equipment ensure that it is completely depressurised. Completely depressurise pressure accumulators.
- Wear personal protective equipment.

2.5.5 Mechanical hazards

Heavy weight of the valve

**WARNING!****Danger of injury due to the heavy weight of the valve!**

The heavy weight of the valve, and of its components, can result in severe injuries.

- Transport valves with a suitable hoist or forklift.
- Don not lift valves via the handwheel.
- Do not lift valves via the actuator.
- If possible, lift valves via the bonnet.
- Use approved and functional sling gear.
- Safeguard valves and components from falling over.

Danger of crushing on stems

**WARNING!****Danger of injury on moving parts!**

Danger of injury exists on moving parts (stems/ anti-twist devices).

- When the valve is in operation do not grasp moving parts.
- Wear personal protective equipment.

2.5.6 Thermal dangers

Thermal dangers



WARNING!

Danger of injury due to high/low temperatures!

Depending on the insert of the valve or of the pipe, injuries can occur due to the high or low temperature of the components.

- When working on components or activating final control equipment, wear protective equipment: Protective gloves, protective goggles.
- Prior to performing tasks on these components, allow them to cool down/warm up to ambient temperature.
- Have the protective insulation provided by the operating company attached.

Danger of freezing



WARNING!

Danger of injury due to pipes shattering at freezing temperatures!

As a result of pipes shattering at freezing temperatures, severe injuries can be caused by fluid under high pressure.

- Ensure that the valve is completely empty before it is taken out of service.
- Never operate valves at temperatures close to, or below the freezing point of the pumping medium.

2.5.7 Danger due to hazardous substances and operating materials

Pumping medium



WARNING!

Danger of injury due to pumping medium under pressure!

In operating status, as well as in decommissioned status, depending on the version of the valve, injuries can occur due to medium escaping under high pressure.

- Do not unscrew threaded connections.
- If threaded connections are loose, inform the operating company and have the pipe section in question shut-off.
- If threaded connections are loose have the cause for this clarified and eliminated. If necessary have the manufacturer check the valve.

**WARNING!****Pumping medium is a health hazard!**

Contact with the pumping medium can have health implications.

- Handle pumping medium in accordance with the instructions in the manufacturer's safety data sheet.
- Wear protective equipment: Protective gloves, safety footwear, protective goggles, protective work clothing.
- Soak up escaped pumping medium without delay and dispose of it in an environmentally responsible manner.

Pickling medium**WARNING!****Pickling medium is a health hazard!**

Direct contact with the pickling medium used can have health implications.

- Handle pickling medium in accordance with the instructions in the manufacturer's safety data sheet.
- Wear protective equipment: Protective gloves, safety footwear, protective goggles, protective work clothing.
- Soak up escaped pickling medium without delay and dispose of it in an environmentally responsible manner.

Anticorrosive**WARNING!****Anticorrosive is a health hazard!**

Direct contact with the anticorrosive used can have health implications.

- Handle anticorrosive in accordance with the instructions in the manufacturer's safety data sheet.
- Wear protective equipment: Protective gloves, safety footwear, protective goggles, protective work clothing.
- Soak up escaped anticorrosive without delay and dispose of it in an environmentally responsible manner.

2.6 Behaviour in the event of an emergency

1. ➤ Shut off the pipe sections affected.
2. ➤ Comply with the plant regulations.

2.7 Responsibility of the operating company

Operating company

The operating company is the company that operates the valve for commercial or economic purposes itself or that provides it to a third party for use, and that, during operation, bears the legal product responsibility for protection of the user, personnel or third parties.

Obligations of the operating company

The valve is used commercially. The operating company of the valve is therefore subject to the legal occupational health and safety obligations.

In addition to the safety instructions in this manual, the local occupational health and safety, accident prevention and environmental protection regulations that apply to the valve's area of application must be observed.

In this regard, the following applies in particular:

- The operating company is responsible for the installation and operation of the valve in the pipe.
- The operating company must ensure that any dangerous situations caused by the operating conditions are avoided by installing additional safety systems.
- The operating company must obtain information about the applicable occupational health and safety regulations and, in a hazard assessment, identify the additional hazards that may exist at the installation site of the valve due to the specific working conditions. The operating company must integrate this information into operating instructions for the operation of the valve.
- The operating company must ensure that the operating instructions it has drawn up comply with the currently applicable legislation throughout the operating period of the valve and, if necessary, adapt the operating instructions.
- The operating company must clearly define and assign the responsibilities for installation, operation, fault correction, maintenance and cleaning.
- After the installation, the operating company must ensure the proper pickling of the valve.
- The operating company must provide equipment that ensures the safe transition of the valve into a depressurized state.
- The operating company must provide equipment that can completely drain the pipe sections in which the valve is installed as well as the valve itself.
- The operating company must ensure that all personnel who are to handle the valve have read and understood this manual. In addition, the operating company must train the personnel and inform them of the hazards at regular intervals.

- The operating company must provide the required protective equipment for the personnel and instruct the personnel that wearing the required protective equipment is compulsory.
- The operating company must install additional protective devices around the valve if contact with the valve can result in injuries due to the medium in the pipe system.

The operating company is also responsible for keeping the valve in proper working order at all times. Therefore, the following applies:

- The operating company must ensure that the maintenance intervals described in these instructions are complied with.
- When using the valve as a throttling valve, the operating company must ensure that the valve is checked for signs of wear on a regular basis.

In the case of valves with different pipe connections on the inlet and outlet sides, the operating company must ensure that when opening the valve the respective pipe connection is not exposed to unduly high pressure or unduly high temperatures.

2.8 Personnel requirements



WARNING!

Danger of injury due to inadequate personnel qualification!

If unqualified personnel perform tasks on the machine or are present in the danger zone, dangers occur that can cause severe injury and significant material damage.

- Only have activities performed by personnel who are qualified to perform these activities.
- Keep unqualified personnel away from the danger zones.

In this manual the qualifications of personnel for the various activity areas are cited below:

Disposal contractor

A disposal contractor is a company qualified in accordance with local regulations to collect, transport, store, handle, recycle or dispose of waste and recyclables.

Forklift truck driver

The forklift truck driver has demonstrated to the operator their skills in driving industrial trucks controlled by a sitting or standing operator and has been assigned to do this by the operator in writing.

Hydraulics Specialist

The Hydraulics Specialist is trained for the special area of responsibility he is involved with and knows the relevant standards and regulations.

Based on his technical training and experience, the Hydraulics Specialist can perform work on hydraulic systems and can recognise and avoid potential hazards himself.

Industrial mechanic (for valves within the normal pressure range)

Based on his or her specialised training, skill, experience and knowledge of the applicable standards and requirements, the industrial mechanic must be able to carry out the assigned work on installations and valves in the normal pressure range and to independently identify potential hazards and avoid them.

The operating company must have instructed the industrial mechanic on how to handle the plant and provide regular training for him or her.

The industrial mechanic must be able to independently maintain and repair installations and valves in the normal pressure range.

Pipeline engineer

Based on their specialised training, skills, experience and knowledge of the applicable standards and provisions, the pipeline engineer is able to carry out the work assigned to them and to independently identify potential hazards and avoid them.

The pipeline engineer is able to install valves safely and properly in the pipework.

Pneumatics Specialist

The Pneumatics Specialist is trained for the special area of responsibility he is involved with and knows the relevant standards and regulations.

Based on his technical training and experience, the Pneumatics Specialist can perform work on pneumatic systems and can recognise and avoid potential hazards himself.

Qualified electrician

The qualified electrician is able to execute tasks on electrical equipment and independently detect and avoid any possible dangers thanks to his training, expertise and experience, as well as knowledge of all applicable regulations.

The qualified electrician has been specially trained for the work environment in which he is active and is familiar with all relevant standards and regulations.

Trained person (hoist)

The trained person (hoist) has been instructed, and can provide evidence of this, by the operator on how to handle the hoist and sling gear and the potential hazards associated with improper behaviour.

Trained person (operator)

The trained person (operator) has been instructed, and can provide evidence of this, by the operating company on how to handle the plant and the potential hazards associated with improper behaviour. This knowledge will be refreshed in regular training provided by the operating company. The trained person (operator) is familiar with the content of this manual.

The trained person (operator) is familiar with the operating company's plant and the associated hazards. They are assigned with operating the plant by the operating company.

Basic requirements

Only persons from whom it is expected that they reliably perform their work are approved as personnel. Persons whose capacity to react is impaired, for example, through drugs, alcohol, or medication are not approved as personnel.

Comply with the age-specific and job-specific regulations that apply at the site of implementation when selecting personnel.

Unauthorised persons**WARNING!****Risk of fatal injury for unauthorised persons due to hazards in the danger zone and work area!**

Unauthorised persons who do not satisfy the requirements described here are not aware of the hazards in the work area. Consequently there is a danger of severe or fatal injuries for unauthorised persons.

- Keep unauthorised persons away from the danger zone and work area.
- If in doubt, speak to these persons and instruct them to leave the danger zone and work area.
- Interrupt tasks as long as unauthorised persons are present in the danger zone and work area.

Instruction

The operating company must instruct personnel on a regular basis. For better tracking an instruction log must be maintained with at least the following content:

- Date of the instruction
- Name of the instructed person
- Content of the instruction
- Name of the instructor
- Signatures of the instructed person and of the instructor

2.9 Personal protective equipment

Personal protective equipment is used to protect personnel from impairments to health and safety at work.

During the various tasks performed on and with the machine, personnel must wear personal protective equipment, to which special reference is made in the individual sections of this manual.

Description of the personal protective equipment

The personal protective equipment is described below:



Chemical resistant safety gloves

Chemical resistant safety gloves are intended to protect hands against aggressive chemicals.



Industrial hard hat

Industrial hard hats protect the head from falling objects, swinging loads and impacts on stationary objects.



Protective gloves

Protective gloves protect hands from friction, abrasion, puncture wounds, or deeper injuries, as well as from contact with hot surfaces.



Protective work clothing

Protective work clothing is tight-fitting work clothing with low resistance to tearing, with tight sleeves, and without projecting parts.



Safety footwear

Safety footwear protects the feet from crushing injuries, falling parts and slipping on a slippery substrate.



Safety goggles

The protective goggles protect the eyes from flying parts and liquid splashes.

2.10 Spare parts

Incorrect spare parts

**WARNING!****Risk of injury if the wrong spare parts are used!**

Using the wrong or defective spare parts may pose a hazard for personnel, or result in damage, malfunctions or even total failure.

- Only use genuine spare parts from Stahl-Armaturen PERSTA GmbH or spare parts approved by Stahl-Armaturen PERSTA GmbH.
- If you have any questions or if anything is unclear, always contact our customer service organisation (contact details on page 3).

Selecting spare parts

**Spare parts recommendation in the scope of delivery**

The spare parts recommendation is included in the scope of delivery of the valve.

Before installation

**Storage of spare parts**

Please see  Chapter 4.4 "Storage of spare parts" on page 43 for information on storing spare parts.

Ordering spare parts

Order spare parts from Stahl-Armaturen PERSTA GmbH, with specification of

- valve type,
- Year of manufacture,
- Nominal diameter,
- Nominal pressure,
- Material,
- Article number,
- Confirmation number,
- Consignment number

(if possible). See page 3 for contact details.

2.11 Environmental protection



ENVIRONMENT!

Hazards for the environment due to improper handling of environmentally-harmful substances!

If environmentally-harmful substances are handled incorrectly, particularly if they are disposed of incorrectly, significant environmental damage can occur.

- Always comply with the instructions cited below for handling and disposal of environmentally-harmful substances.
- Comply with the guidelines for disposal of environmentally hazardous substances issued by the operating company.
- If environmentally-harmful substances inadvertently get into the environment, immediately implement suitable measures. If in doubt, inform the responsible municipal authorities of the damage and ask about suitable measures that should be implemented.

Substances used

The following environmentally harmful substances are used:

- Lubricant for stem and bearing
- Residue of the pipeline medium
- Pickling medium
- Anticorrosive
- With hydraulic actuator: hydraulic fluid

3 Functional description

3.1 Operating principle of the shut-off valve

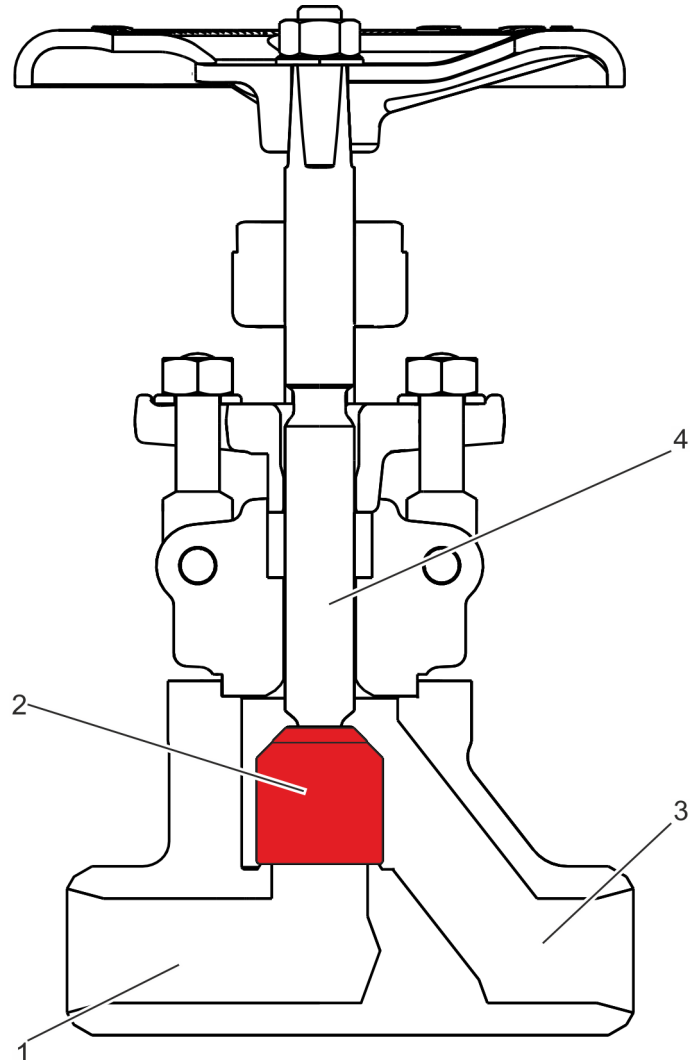

Fig. 8: Sectional view

In the closed state, the shut-off element (Fig. 8/2) separates the inlet side (Fig. 8/1) from the outlet side (Fig. 8/3) of the valve. The shut-off element is moved to the interior of the valve via a stem (Fig. 8/4). The shut-off valves are distinguished as follows:

- Type of shut-off element
- Type of actuator
- Type of connection
- Body shape

Moreover, it is possible that the valve has display elements.

3.2 Versions of the shut-off valve

3.2.1 External seal

The sealing of the stem against the environment is shown below.

Gland packing

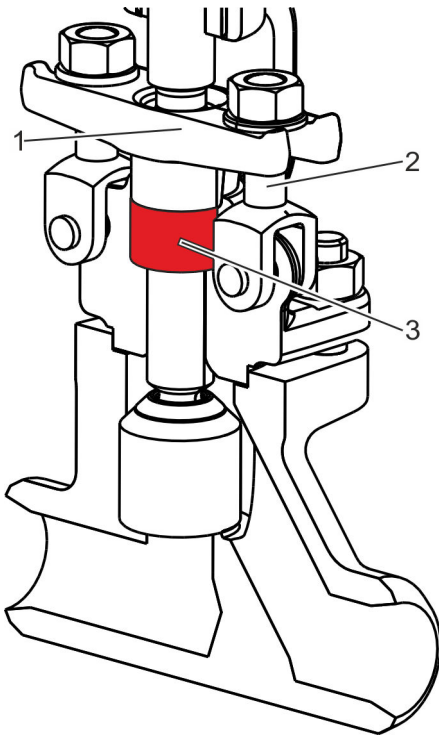

The gland packing seals the stem off against the environment. For this the gland follower flange (Fig. 9/1) is pressed onto the packing elements (Fig. 9/3) using stud bolts (Fig. 9/2). The resulting transverse deformation and the axial tensioning of the packing elements causes the stem to be sealed off against the medium.

Fig. 9: Gland packing

Bellows

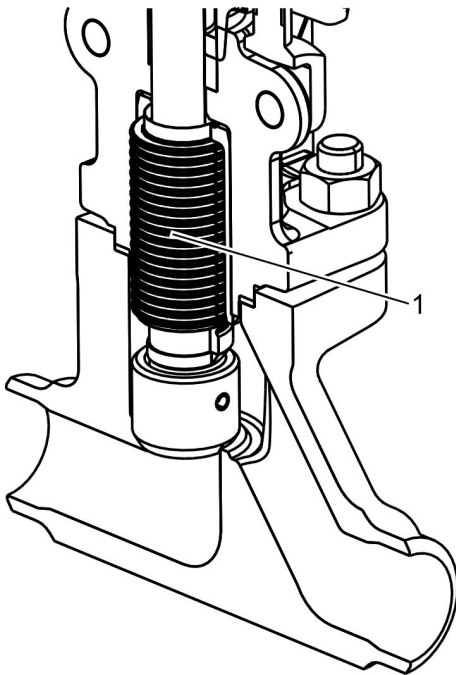

Fig. 10: Bellows

The bellows (Fig. 10/1) is welded onto the shut-off element and cover and seals off hermetically against the environment.

The bellows is maintenance-free and is replaced along with the stem when its service life expires.

The stem does not come into contact with the medium.

Versions of the packing bolts

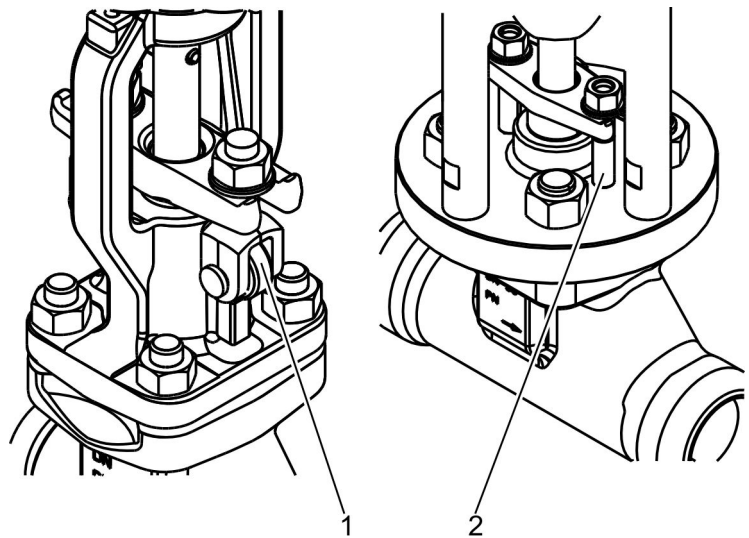

Fig. 11: Packing bolts

Depending on the version, there are hinged eyebolts (Fig. 11/1) or stud bolts (Fig. 11/2).



Optional life loaded packing

The stuffing box compression can be applied via a life loaded packing.

3.2.2 Shut-off element

Variants of shut-off elements

The shut-off valves can be equipped with the following cone types:

- Throttling valve cone
- Shut-off cone

Throttling valve cone

The throttling valve cone is used if a valve is used for (short-term) throttling operation.

Shut-off cone

The shut-off valve cone is used if a valve is used for open/close operation.

3.2.3 Actuator variants

Manual actuator (handwheel)

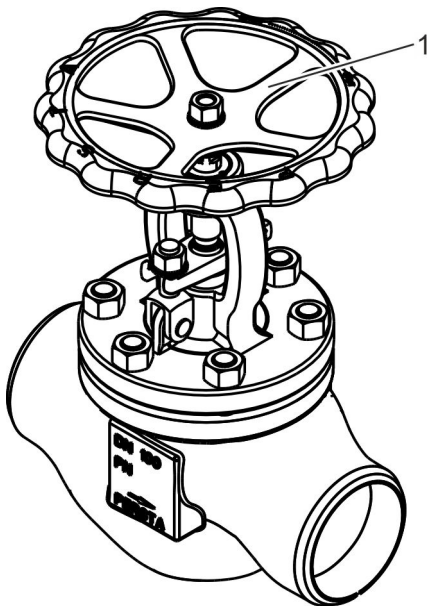

The stem is driven manually with the handwheel (Fig. 12/1).

The handwheel can be attached in the following manner:

- Direct attachment
- Bevel gearbox with handwheel
- Spur gearbox with handwheel
- Remote actuator

Fig. 12: Manual actuator

Electric actuator

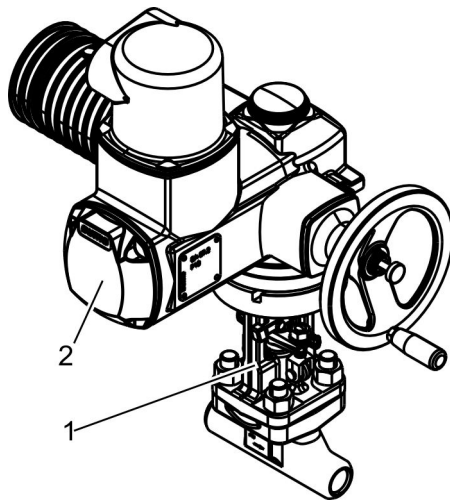

Fig. 13: Electric actuator

With the optional electric actuator, the stem is driven by an electric motor (Fig. 13/2). The electric motor is connected to the valve and the threaded bush above the bonnet (Fig. 13/1).

The electric actuator is adjusted in the opening direction via limit switches by the manufacturer.

The electric actuator is adjusted in the closing direction via torque.

The electric actuator can be attached in the following manner:

- Direct attachment of the electric actuator
- Bevel gearbox with electric actuator
- Spur gearbox with electric actuator
- Remote actuator

Hydraulic actuator

With the optional hydraulic actuator, the stem is driven axially by a hydraulic piston actuator.

The hydraulic actuator is connected to the bonnet. Valve stem and piston rod are equipped with adjustable coupling pieces.

Pneumatic actuator

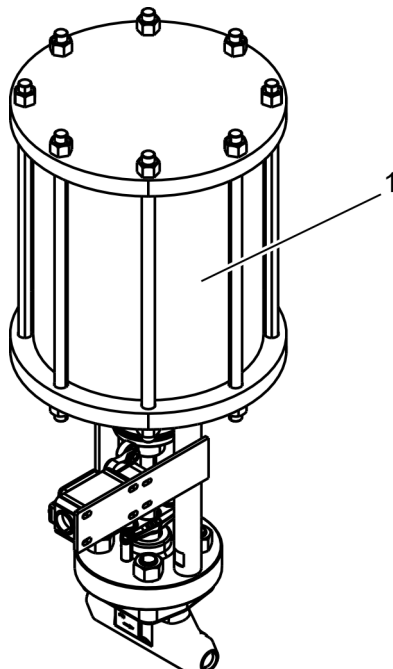

Fig. 14: Pneumatic actuator

With the optional pneumatic actuator, the stem is driven axially by a pneumatic piston actuator (Fig. 14/1).

The pneumatic actuator is connected to the bonnet. Valve stem and piston rod are equipped with adjustable coupling pieces.

3.2.4 Body shape

T-pattern

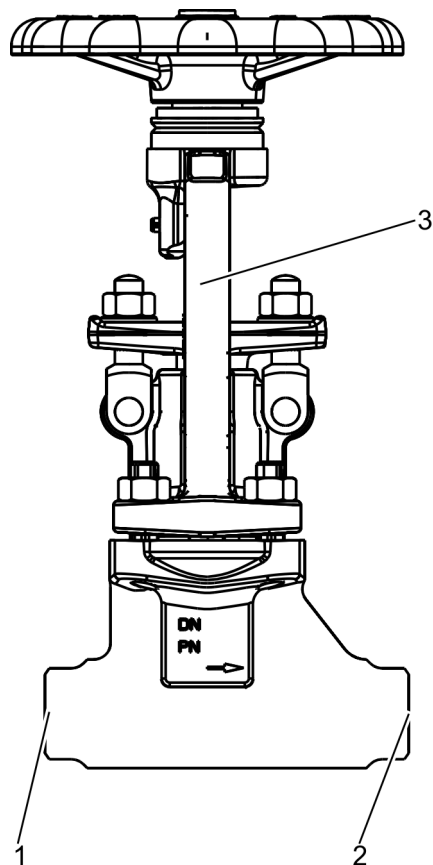
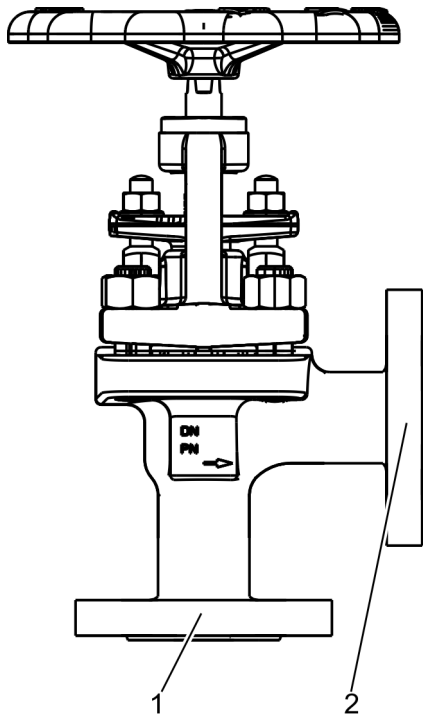

Fig. 15: T-pattern

With the T-pattern, the stem (Fig. 15/3) is mounted vertically.

The inlet side (Fig. 15/1) is on one axis with the outlet side (Fig. 15/2) of the valve.

Angle pattern valve



With the version of the valve as an angle pattern valve, the inlet side (Fig. 16/1) is arranged at right angles to the outlet side (Fig. 16/2).

Fig. 16: Angle pattern valve

Shuttle valve

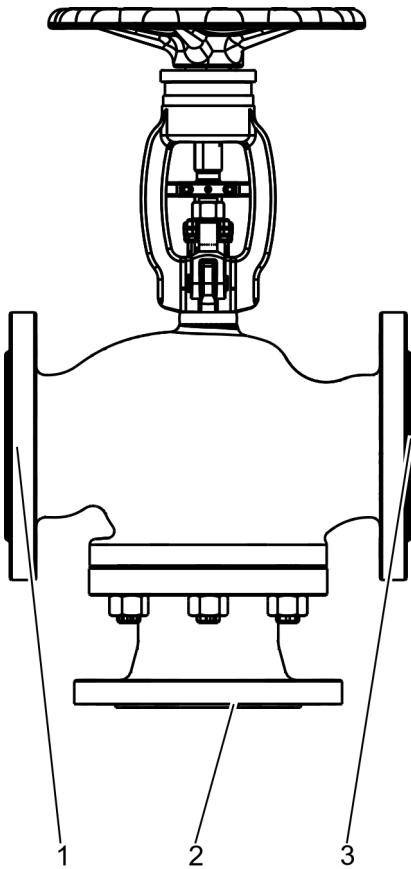

Fig. 17: Three flange connections

With a shuttle valve, the valve has one inlet side (Fig. 17/1) and two outlet sides (Fig. 17/2 and 3).

Depending on the position of the stem, the medium flows from the inlet side through one of the two outlet sides.



Shut-off

With a shuttle valve, one outlet side is always open, while the other side is closed.



NOTICE!

Increased wear of the shut-off element!

If the valve is used as a mixing valve (middle position of the shut-off element), component wear will increase.

- Check the shut-off element and stem at regular intervals for wear.

Z shape

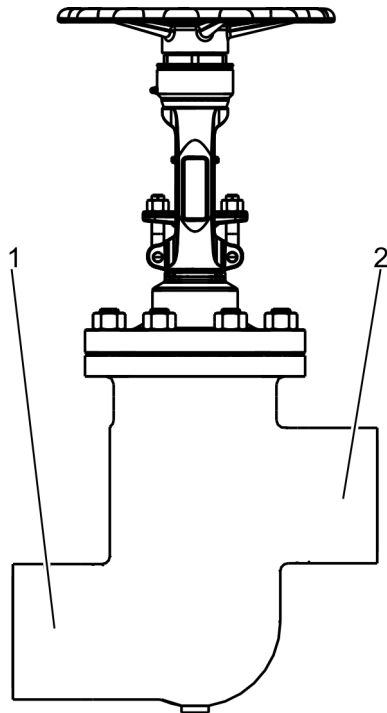

Fig. 18: Offset axis

With the Z shape, the axis of the inlet side (Fig. 18/1) is below the axis of the outlet side (Fig. 18/2).



Due to the Z shape of the body, the pipe on the outlet side can be drained completely.

3.2.5 Display elements

Position indicator (visualised)

An electrical position indicator (limit switch or inductive proximity switch) is optionally available for the valve. The display indicates whether the valve position is open or closed.

Position indicator (mechanical)

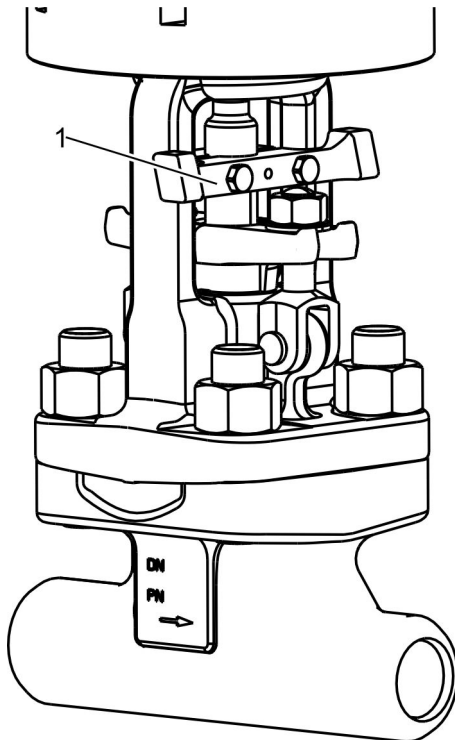

Fig. 19: Mechanical position indicator

The valve has a mechanical position indicator (Fig. 19/1).

The crossbar (Fig. 19/1) attached to the stem indicates the position of the shut-off element.

- Shut-off element closed: Crossbar in the lower position
- Shut-off element open: Crossbar in the upper position

The crossbar also acts as a shifting claw for operating limit switches for controlling an optional actuator (electric, hydraulic or pneumatic).

The crossbar also prevents the stem from twisting.

3.3 Connections

Connection in the pipe

Depending on the version, the shut-off valve can be installed in the pipe in different ways.

- Installation as butt-weld valve
- Installation as flanged valve
- Installation as socket weld valve
- Installation as special connection valve

Electrical connections

A connection for the customer-provided power supply is provided on the electric actuator.



Information on the connection is provided in the operating instructions for the electric actuator.

Hydraulic connections

Connections for the customer-provided hydraulic supply are provided on the flanges or on the control valves on the hydraulic piston actuator.



Information on the connection is provided in the operating instructions for the hydraulic actuator.

Pneumatic connections

Connections for the customer-provided pneumatic supply are provided on the flanges or on the control valves on the pneumatic piston actuator.



Information on the connection is provided in the operating instructions for the pneumatic actuator.

4 Transport and storage

4.1 Safety instructions for transport and storage

Heavy weight of the valve

**WARNING!****Risk of injury due to the heavy weight of the valve!**

The heavy weight of the valve and its components can cause severe injuries.

- Transport valves with a suitable hoist or forklift.
- Use approved and functioning sling gear.
- Secure valves and components against falling over.

Suspended loads

**WARNING!****Danger of injury due to suspended loads!**

Suspended loads can cause dangerous situations that can result in severe injuries.

- Do not step under suspended loads.
- Wear protective equipment: Industrial hard hat, safety footwear.
- Transport loads as close to the ground as possible.
- Only use approved sling gear and hoists.
- Ensure that hoist and sling gear have sufficient load-bearing capacity.

Improper transport

**NOTICE!****Material damage due to improper transport!**

Valves can fall or tip over if transported improperly. This can cause considerable material damage.

- When unloading valves at delivery, as well as for inner-company transport, proceed carefully and pay attention to the symbols and instructions on the packaging.
- If present: Use the provided ring bolts and ring nuts.
- Protect valves from impacts.
- Do not throw valves.
- Only remove the packaging just before installation.

4.2 Transport of packages

Depending on the size, valves are delivered individually or on a pallet.

Transporting individual valves

- | | |
|-----------------------|--------------------------|
| Personnel: | ■ Trained person (hoist) |
| Protective equipment: | ■ Industrial hard hat |
| | ■ Protective gloves |
| | ■ Safety footwear |
| Special tool: | ■ Sling gear |
| | ■ Hoist |

1. ▶



DANGER!
Unmarked attachment points!

Fasten valve onto the hoist with suitable sling gear.

2. ▶ Slowly lift the valve and identify the position of the centre of gravity.
3. ▶ Transport the valve as close to the ground as possible.
4. ▶ After setting down the valve, safeguard it from falling over.

Transport on a pallet

- | | |
|-----------------------|--------------------------|
| Personnel: | ■ Forklift truck driver |
| | ■ Trained person (hoist) |
| Protective equipment: | ■ Industrial hard hat |
| | ■ Protective gloves |
| | ■ Safety footwear |
| Special tool: | ■ Sling gear |
| | ■ Hoist |
| | ■ Forklift |

1. ▶ Ensure that the valve is fixed in place on the pallet.
2. ▶ Transport the pallet to the installation location.
3. ▶ Unload heavy valves from the pallet with a suitable hoist and further transport.

4.3 Storage of the valve

Storage of the valve

Store valves under the following conditions:

- Store valve in closed status (delivery status).
- Do not store outdoors.
- Store in a dry and dust-free location.
- Do not expose to any aggressive media.
- Protect from direct sunlight.
- Avoid mechanical vibrations.
- Storage temperature: 15–35°C.
- Relative humidity: max. 60%.
- Check the status of the protective caps attached in the factory. Replace protective caps if necessary.
- When storing for longer than 3 months, check the general condition of all parts and the packaging on a regular basis. Touch up or reapply anti-corrosion agents as needed.



It may be the case that storage instructions are affixed to the packages that extend beyond the requirements cited here. Comply with these instructions accordingly.

4.4 Storage of spare parts

Reduced service life



NOTICE!

Material damage due to reduced service life if stored incorrectly!

A shortened service life may result from incorrect storage of the soft-sealing spare parts.

- Store soft-sealing elements, plastics or lubricants in a dry location at room temperature where they are protected against light.

Storage of spare parts

5 Installation

5.1 Safety instructions for installation

Electric shock

**DANGER!****Risk of fatal injury from electric shock!**

There is a risk of fatal injury when touching live components of the actuator. Switched-on electrical components can execute uncontrolled movements and can cause serious injuries.

- Prior to starting work, switch off the supply of electricity and definitively disconnect it.
- Only have an electrician perform tasks on electrical lines and components.

Fluid under high pressure

**WARNING!****Danger of injury due to hydraulic energy!**

Hydraulically-powered components of the valve, as well as the triggering of the overpressure valve can cause severe injuries.

- Only have specialised personnel perform tasks on the hydraulic system.
- Prior to starting the tasks on the hydraulic system ensure that it is completely depressurised. Completely depressurise pressure accumulators.
- Operate the valve in a frost-free environment to prevent the body from bursting.
- Wear personal protective equipment.

Hazards associated with the pneumatic system

**WARNING!****Danger of injury due to pneumatic energy!**

Pneumatically-powered components of the valve, can cause severe injuries.

- Only have pneumatic specialists perform tasks on the pneumatic equipment.
- Prior to starting the tasks on the pneumatic equipment ensure that it is completely depressurised. Completely depressurise pressure accumulators.
- Wear personal protective equipment.

Faulty installation



WARNING!

Risk of injury due to incorrectly installed valve!

A faulty installation may result in injuries due to a malfunction of the valve.

- Pay attention to the correct flow direction of the valve (↺ “Flow direction arrow” on page 15).
- Pay attention to the correct installation position of the valve (↺ Chapter 11 “Technical data” on page 99).
- In the case of valves with an actuator or transmission, ensure that the stem position is vertical.
- In special cases and if the stem position is not vertical:
 - Support the actuator on the valve head.
 - Ensure that the actuator can follow the position changes of the pipe.
- With butt-weld valves
 - Prior to welding on, open the valve completely
 - Fasten the welding counterpole on the body, if possible in the vicinity of the welding point
 - Perform welding and subsequent heat treatment in compliance with the applicable welding regulations
 - Perform partial thermal treatment.

Wrong bolt tightening torques



WARNING!

Hazard risk due to wrong tightening torques!

The tightening torques for the threaded connections on the valve have been calculated and applied by the manufacturer. Hazards may occur due to unscrewing and subsequent tightening if the wrong tightening torques are used.

- Do not undo the threaded connections on the valve.
- For maintenance work or if the threaded connections have become loose, request the tightening torques by:
 - Contacting Stahl-Armaturen PERSTA GmbH customer service (see page 4) specifying the serial number, or
 - Refer to the manufacturer’s website (see page 3).

Incorrect alignment of the valve



NOTICE!

Malfunction of the valve due to failure to observe the flow direction!

An incorrect alignment can result in the entire plant malfunctioning.

- Install the valve in accordance with the flow direction arrow (☞ “Flow direction arrow” on page 15) and the flow direction in the pipe.

5.2 Before the installation

- | | |
|-----------------------|----------------------------|
| Personnel: | ■ Pipeline engineer |
| Protective equipment: | ■ Protective work clothing |
| | ■ Protective gloves |
| | ■ Industrial hard hat |
| | ■ Safety footwear |

1. ➤ Check design parameters and material.
2. ➤ Pay attention to the installation position.
3. ➤ Pay attention to the flow direction.
4. ➤ For butt-weld valves, completely open the butt-weld valve.
5. ➤ Remove any protective caps and preservation agent from the valve.
6. ➤ Ensure that there are no objects or materials in the interior of the valve.

5.3 Installing the valve

- | | |
|-----------------------|----------------------------|
| Personnel: | ■ Pipeline engineer |
| | ■ Trained person (hoist) |
| Protective equipment: | ■ Protective work clothing |
| | ■ Protective gloves |
| | ■ Industrial hard hat |
| | ■ Safety footwear |
| Special tool: | ■ Sling gear |
| | ■ Hoist |

1. ➤ Prepare the respective pipe section for the installation.
2. ➤ Use a hoist to bring the valve into installation position.
3. ➤ Ensure that the customer-provided pipes are free of tension.
4. ➤ Ensure that the customer-provided pipes are free of external forces and torques.

For electric actuators, connect the power supply

5. ▶ Check butt-weld ends and flange sealing surfaces for damage and cleanliness.
6. ▶ Centre the connection flange.
7. ▶ Use connection elements and sealing elements made of permissible materials.
8. ▶ Depending on the type of connection, weld in or flange on valve in the correct flow direction and installation position.
9. ▶ Screw together all flange bores with connection elements using the permissible tightening torque.
10. ▶ For valves with actuators or transmissions (electric/hydraulic/pneumatic), ensure that the stem position is vertical.
11. ▶ For a different installation position, prop up the actuator and ensure that the actuator can follow the position changes of the pipe.
12. ▶ Ensure the seal of the pipe and the valve.

5.4 For electric actuators, connect the power supply

- Personnel: ■ Qualified electrician
- Protective equipment: ■ Protective work clothing
■ Safety footwear

Prerequisite:

- Ensure that the customer-provided power supply is switched off and safeguarded against being switched on again.

1. ▶



Terminal diagram and operating manual are located on the actuator.

Connect the electric actuator of the valve to the customer-provided power supply in accordance with the provided terminal diagram.

2. ▶ Avoid mechanical stress of the cable through suitable installation.
3. ▶ Protect the cable against contact with hazardous substances and operating materials.
4. ▶ Install the cable in such a manner that there are no trip hazards.

5.5 For a hydraulic actuator, connecting the hydraulic system

- Personnel: ■ Hydraulics Specialist
- Protective equipment: ■ Safety goggles
■ Protective work clothing
■ Safety footwear

1. ➤ Switch off the customer-provided hydraulic supply and safeguard it from being switched on again.
2. ➤ Connect the hydraulic actuator of the valve to the customer-provided hydraulic supply in accordance with the provided connection plan.
3. ➤ Avoid mechanical stress of the hydraulic line through suitable installation.
4. ➤ Protect the hydraulic line against contact with hazardous substances and operating materials.
5. ➤ Install lines in such a manner that there are no trip hazards.

5.6 For a pneumatic actuator, connecting the pneumatic system

- Personnel: ■ Pneumatics Specialist
- Protective equipment: ■ Safety goggles
■ Protective work clothing
■ Safety footwear

1. ➤ Switch off the customer-provided pneumatic supply and safeguard it from being switched on again.
2. ➤ Connect the pneumatic actuator of the valve to the customer-provided pneumatic supply in accordance with the provided connection plan.
3. ➤ Avoid mechanical stress of the pneumatic line through suitable installation.
4. ➤ Protect the pneumatic line against contact with hazardous substances and operating materials.
5. ➤ Install lines in such a manner that there are no trip hazards.

5.7 After the installation

Harmful substances



WARNING!

Pickling medium is a health hazard!

Direct contact with the pickling medium used can have health implications.

- Handle pickling medium in accordance with the instructions in the manufacturer's safety data sheet.
- Wear protective equipment: Protective gloves, safety footwear, protective goggles, protective work clothing.
- Soak up escaped pickling medium without delay and dispose of it in an environmentally responsible manner.



WARNING!

Gloss paint is a health hazard!

Direct contact with the gloss paint used can have health implications.

- Handle gloss paint in accordance with the instructions in the manufacturer's safety data sheet.
- Wear protective equipment: Protective gloves, safety footwear, protective goggles.



WARNING!

Anticorrosive is a health hazard!

Direct contact with the anticorrosive used can have health implications.

- Handle anticorrosive in accordance with the instructions in the manufacturer's safety data sheet.
- Wear protective equipment: Protective gloves, safety footwear, protective goggles, protective work clothing.
- Soak up escaped anticorrosive without delay and dispose of it in an environmentally responsible manner.

5.7.1 Pickling the valve



It is possible to pickle the valve in many ways.

Ensure that the operating company's specialised personnel pickle the valve.

- Personnel: ■ Pipeline engineer
- Protective equipment: ■ Safety goggles
 ■ Protective work clothing
 ■ Chemical resistant safety gloves
 ■ Safety footwear

1. ➤ During the pickling process, completely open the valve.
2. ➤ For valves with backseat: Drive the stem into the backseat.
3. ➤ Properly pickle the valve.
4. ➤ Close the valve half way after the pickling process.
5. ➤ Completely remove the pickling medium by rinsing.
6. ➤ Ensure that the pickling medium is completely flushed out of the dead spaces in the valve.

5.7.2 Painting the valve



Ensure that the operating company's specialised personnel paint the valve.

Use suitable (compatible) painting systems.

5.7.3 Executing the system pressure test and leak test

- Personnel: ■ Pipeline engineer
- Protective equipment: ■ Industrial hard hat
 ■ Safety goggles
 ■ Protective work clothing
 ■ Protective gloves
 ■ Safety footwear

1. ➤ Execute tests in accordance with local regulations.
2. ➤ Release the pipe after successful tests.
3. ➤ For longer idle periods after the hydrostatic pressure test, completely open the valve.

4. ➤ For longer idle periods after the hydrostatic pressure test, replace the anticorrosive in consultation with the manufacturer.

5.7.4 Applying thermal insulation



System-specific equipment

Depending on the system, it may be necessary to equip the pipe or the valve with thermal insulation.

- Personnel: ■ Pipeline engineer
- Protective equipment: ■ Safety goggles
■ Protective work clothing
■ Protective gloves
■ Safety footwear

1. ➤ If necessary, have the thermal insulation attached by the operating company.
2. ➤ Ensure that all operating elements and stuffing box areas remain permanently accessible and controllable.

The insulation must only reach the upper edge of the bonnet flange (Fig. 20, red arrow).

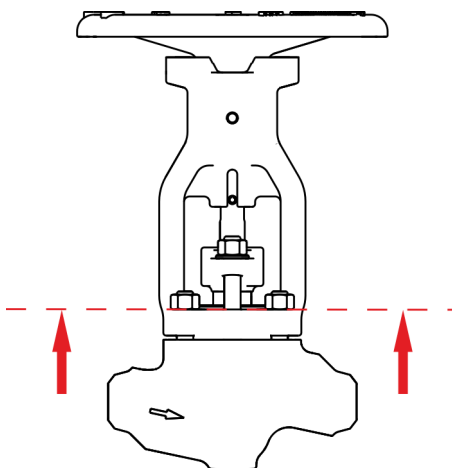

Fig. 20: Upper edge of the insulation

6 Initial start-up

6.1 Safety instructions for initial start-up

Danger of freezing

**WARNING!****Danger of injury due to pipes shattering at freezing temperatures!**

As a result of pipes shattering at freezing temperatures, severe injuries can be caused by fluid under high pressure.

- Ensure that the valve is completely empty before it is taken out of service.
- Never operate valves at temperatures close to, or below the freezing point of the pumping medium.

Pumping medium

**WARNING!****Danger of injury due to pumping medium under pressure!**

In operating status, as well as in decommissioned status, depending on the version of the valve, injuries can occur due to medium escaping under high pressure.

- Do not unscrew threaded connections.
- If threaded connections are loose, inform the operating company and have the pipe section in question shut-off.
- If threaded connections are loose have the cause for this clarified and eliminated. If necessary have the manufacturer check the valve.

**WARNING!****Pumping medium is a health hazard!**

Contact with the pumping medium can have health implications.

- Handle pumping medium in accordance with the instructions in the manufacturer's safety data sheet.
- Wear protective equipment: Protective gloves, safety footwear, protective goggles, protective work clothing.
- Soak up escaped pumping medium without delay and dispose of it in an environmentally responsible manner.

Failure to comply with the heating-up times/cooling times



WARNING!

Danger of injury due to failure to comply with the heating-up times/cooling times!

Insufficient heating-up times/cooling times may lead to impermissible deformations of the valve and reduction of the total service life.

- Comply with the heating-up times/cooling times (max. 6 K/min (6 °C/min)).
- If in doubt consult with the manufacturer.

Thermal dangers



WARNING!

Danger of injury due to high/low temperatures!

Depending on the insert of the valve or of the pipe, injuries can occur due to the high or low temperature of the components.

- When working on components or activating final control equipment, wear protective equipment: Protective gloves, protective goggles.
- Prior to performing tasks on these components, allow them to cool down/warm up to ambient temperature.
- Have the protective insulation provided by the operating company attached.

Danger of crushing on stems



WARNING!

Danger of injury on moving parts!

Danger of injury exists on moving parts (stems/anti-twist devices).

- When the valve is in operation do not grasp moving parts.

Wrong bolt tightening torques

**WARNING!****Hazard risk due to wrong tightening torques!**

The tightening torques for the threaded connections on the valve have been calculated and applied by the manufacturer. Hazards may occur due to unscrewing and subsequent tightening if the wrong tightening torques are used.

- Do not undo the threaded connections on the valve.
- For maintenance work or if the threaded connections have become loose, request the tightening torques by:
 - Contacting Stahl-Armaturen PERSTA GmbH customer service (see page 4) specifying the serial number, or
 - Refer to the manufacturer's website (see page 3).

6.2 Before commissioning

- Personnel: ■ Pipeline engineer
- Protective equipment: ■ Industrial hard hat
 ■ Safety goggles
 ■ Protective work clothing
 ■ Protective gloves
 ■ Safety footwear

1. ➤ Ensure that the entire plant has been released for operation.

Operating a valve with manual actuator

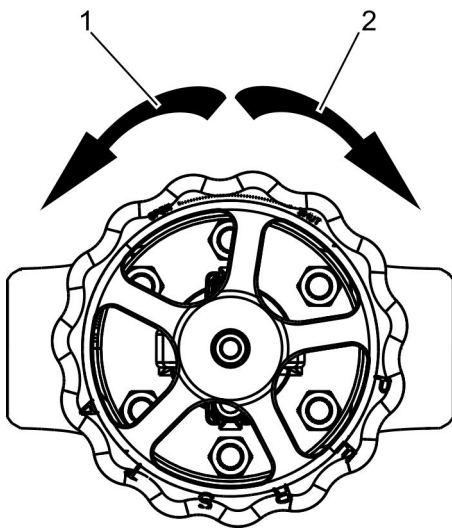

2. ➤ Fully open the valve by turning the handwheel anticlockwise (Fig. 21/1) ("Open").

3. ➤ Fully close the valve by turning the handwheel clockwise (Fig. 21/2) ("Shut").

4. ➤ Repeat step 2–3 several times.

Fig. 21: Valve: Top view

Valve with electric, hydraulic or pneumatic actuator

5. ➤ Open and close valve several times using the higher-level or local control system.

6.3 Carrying out initial start-up

- | | |
|-----------------------|---|
| Personnel: | <ul style="list-style-type: none">■ Pipeline engineer■ Industrial mechanic (for valves within the normal pressure range) |
| Protective equipment: | <ul style="list-style-type: none">■ Industrial hard hat■ Safety goggles■ Protective work clothing■ Protective gloves■ Safety footwear |

1. ➤



WARNING!

Failure to comply with the heating/cooling times!

Fill the pipe or open the shut-off pipe section in accordance with the plant-specific heating-up or cooling-down speed.

2. ➤ Check the stuffing box area for leaks.
3. ➤ Check the pipe connection flanges for leaks.
4. ➤ If necessary, recheck tightening torques in accordance with the manufacturer's/system planner's specifications.

Carrying out initial start-up

7 Operation

7.1 Safety instructions for operation

Pumping medium

**WARNING!****Danger of injury due to pumping medium under pressure!**

In operating status, as well as in decommissioned status, depending on the version of the valve, injuries can occur due to medium escaping under high pressure.

- Do not unscrew threaded connections.
- If threaded connections are loose, inform the operating company and have the pipe section in question shut-off.
- If threaded connections are loose have the cause for this clarified and eliminated. If necessary have the manufacturer check the valve.

**WARNING!****Pumping medium is a health hazard!**

Contact with the pumping medium can have health implications.

- Handle pumping medium in accordance with the instructions in the manufacturer's safety data sheet.
- Wear protective equipment: Protective gloves, safety footwear, protective goggles, protective work clothing.
- Soak up escaped pumping medium without delay and dispose of it in an environmentally responsible manner.

Thermal dangers

**WARNING!****Danger of injury due to high/low temperatures!**

Depending on the insert of the valve or of the pipe, injuries can occur due to the high or low temperature of the components.

- When working on components or activating final control equipment, wear protective equipment: Protective gloves, protective goggles.
- Prior to performing tasks on these components, allow them to cool down/warm up to ambient temperature.
- Have the protective insulation provided by the operating company attached.

Improper operation of the handwheel



WARNING!

Danger of injury due to force-increasing objects!

Through the use of force increasing objects (rods/tubes) as levers for actuating the handwheel, injuries can occur due to damage of components in the force flow.

- Do not use any force increasing objects to activate the handwheel.
- Only activate the handwheel by hand.
- If the handwheel does not move easily, or if it cannot be activated, lubricate the stem thread and bearing and if necessary, contact the manufacturer (contact details p.3).

Increased wear



NOTICE!

Material damage due to excessive use as throttling valve!

Excessive use of the valve as throttling valve can result in malfunction and material damage due to overstressing of the components.

- Only use the valve briefly as throttling valve.
- In normal operation use the valve as open/close valve.
- Have the maintenance and replacement intervals shortened by the operating company depending on the use of the valve.

7.2 Operating the valve

Operating a valve with manual actuator

- | | |
|-----------------------|---|
| Personnel: | <ul style="list-style-type: none"> ■ Industrial mechanic (for valves within the normal pressure range) ■ Trained person (operator) |
| Protective equipment: | <ul style="list-style-type: none"> ■ Industrial hard hat ■ Safety goggles ■ Protective work clothing ■ Protective gloves ■ Safety footwear |

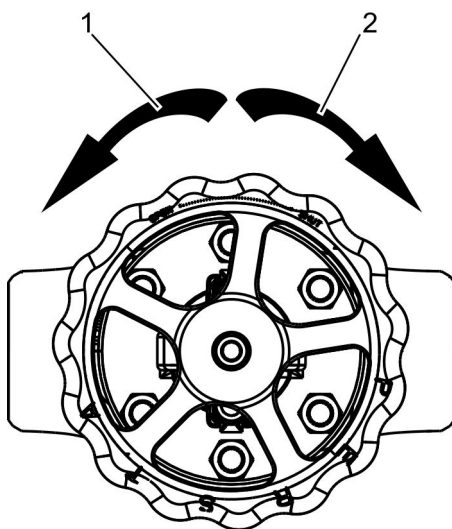

- Turn handwheel on the valve:
- Turning clockwise (Fig. 22/2): Closes the valve ("Shut").
 - Turning anticlockwise (Fig. 22/1): Opens the valve ("Open").

Fig. 22: Manual actuator: Turning the handwheel

Operating a valve with electric actuator



The valve is operated using the higher-level or local control system.

Operating a valve with hydraulic or pneumatic actuator



The valve is operated using the higher-level or local control system.

7.3 Operating the valve in an emergency



Comply with the operating company's instructions concerning behaviour in the event of an emergency.

Operating a valve with manual actuator in an emergency

- | | |
|-----------------------|---|
| Personnel: | <ul style="list-style-type: none"> ■ Industrial mechanic (for valves within the normal pressure range) ■ Trained person (operator) |
| Protective equipment: | <ul style="list-style-type: none"> ■ Industrial hard hat ■ Safety goggles ■ Protective work clothing ■ Protective gloves ■ Safety footwear |

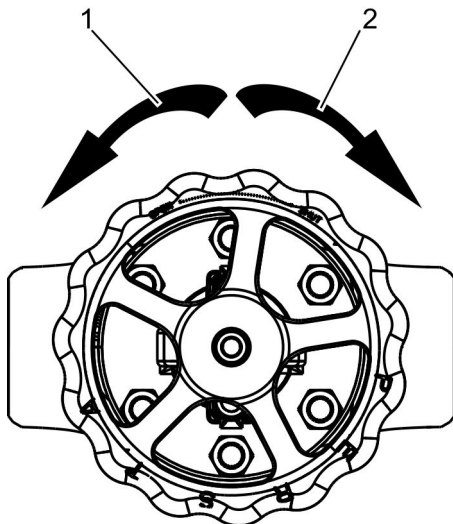

- Turn the handwheel.
- Turning clockwise (Fig. 23/2): Closes the valve ("Shut").
 - Turning anticlockwise (Fig. 23/1): Opens the valve ("Open").

Fig. 23: Manual actuator: Operating the handwheel in an emergency

Operating a valve with electric actuator in an emergency



Coupling/uncoupling the handwheel

See the documentation for the electric actuator for information on coupling and uncoupling the handwheel for emergency operation of the valve.

- Personnel:
- Industrial mechanic (for valves within the normal pressure range)
 - Trained person (operator)
- Protective equipment:
- Industrial hard hat
 - Safety goggles
 - Protective work clothing
 - Protective gloves
 - Safety footwear

Requirement:

- The electric actuator cannot be used.

1. ➤ Safeguard the affected system area.
2. ➤ Couple the handwheel (Fig. 24/3).
3. ➤ Turn the handwheel.
 - Turning clockwise (Fig. 24/2): Closes the valve.
 - Turning anticlockwise (Fig. 24/3): Opens the valve.

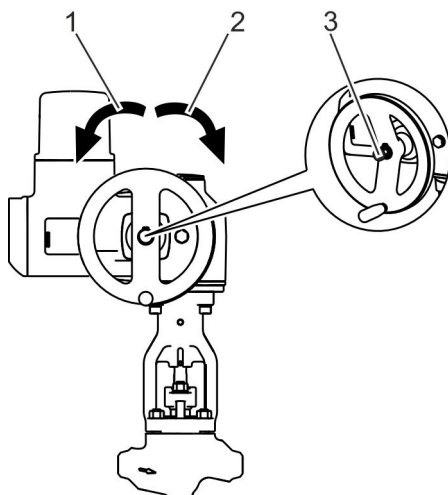

Fig. 24: Electric actuator: Operating the handwheel in an emergency

Operating a valve with hydraulic or pneumatic actuator in an emergency



Operating a hydraulic or pneumatic actuator in an emergency

See the documentation for the hydraulic or electric actuator for information on emergency operation of the valve.

Operating the valve in an emergency

8 Maintenance

8.1 Safety instructions for maintenance

Safeguard against restart

**DANGER!****Life-threatening danger due to unintended restart!**

The unauthorised switch-on of the energy supply during work poses a danger of severe or fatal injuries for persons in the danger zone.

- Prior to beginning work, switch off all energy supplies and safeguard them from being switched on again.
- Safeguard the system area.

Hazards associated with the pneumatic system

**WARNING!****Danger of injury due to pneumatic energy!**

Pneumatically-powered components of the valve, can cause severe injuries.

- Only have pneumatic specialists perform tasks on the pneumatic equipment.
- Prior to starting the tasks on the pneumatic equipment ensure that it is completely depressurised. Completely depressurise pressure accumulators.
- Wear personal protective equipment.

Fluid under high pressure

**WARNING!****Danger of injury due to hydraulic energy!**

Hydraulically-powered components of the valve, as well as the triggering of the overpressure valve can cause severe injuries.

- Only have specialised personnel perform tasks on the hydraulic system.
- Prior to starting the tasks on the hydraulic system ensure that it is completely depressurised. Completely depressurise pressure accumulators.
- Operate the valve in a frost-free environment to prevent the body from bursting.
- Wear personal protective equipment.

Improperly executed maintenance tasks



WARNING!

Danger of injury due to improperly executed maintenance tasks!

Improper maintenance can cause severe injury or significant material damage.

- Before starting tasks:
 - ensure that there is adequate free space for installation,
 - ensure that the valve is depressurised,
 - ensure that the valve is cooled-down/ warmed-up to ambient temperature,
 - Ensure that the upstream and downstream system for the valve are reliably sealed.
- Ensure order and cleanliness at the installation location! Loosely stacked components or components and tools that are lying about can cause accidents.
- Comply with the following before restarting the system:
 - Ensure that all maintenance tasks have been properly executed and concluded in accordance with the instructions in this manual.
 - Ensure that nobody is in the danger zone.
 - Ensure that all covers and protective devices are installed correctly and that they function properly.

Pressurised components



WARNING!

Danger of injury due to pressurised components!

Tasks on pressurised components can result in serious injuries.

- Establish depressurised status before working on the valve.

Heavy weight of the valve**WARNING!****Danger of injury due to the heavy weight of the valve!**

The heavy weight of the valve, and of its components, can result in severe injuries.

- Transport valves with a suitable hoist or forklift.
- Don not lift valves via the handwheel.
- Do not lift valves via the actuator.
- If possible, lift valves via the bonnet.
- Use approved and functional sling gear.
- Safeguard valves and components from falling over.

Thermal hazards**WARNING!****Danger of injury due to high/low temperatures!**

Depending on the insert of the valve or of the pipe, injuries can occur due to the high or low temperature of the components.

- When working on components or activating final control equipment, wear protective equipment: Protective gloves, protective goggles.
- Prior to performing tasks on these components, allow them to cool down/warm up to ambient temperature.
- Have the protective insulation provided by the operating company attached.

Wrong bolt tightening torques



WARNING!

Hazard risk due to wrong tightening torques!

The tightening torques for the threaded connections on the valve have been calculated and applied by the manufacturer. Hazards may occur due to unscrewing and subsequent tightening if the wrong tightening torques are used.

- Do not undo the threaded connections on the valve.
- For maintenance work or if the threaded connections have become loose, request the tightening torques by:
 - Contacting Stahl-Armaturen PERSTA GmbH customer service (see page 4) specifying the serial number, or
 - Refer to the manufacturer's website (see page 3).

Wrong spare parts



WARNING!

Danger of injury if the wrong spare parts are used!

Using the wrong or defective spare parts may result in dangers for personnel and damage, malfunction or total machine failure.

- Only use original spare parts from Stahl-Armaturen PERSTA GmbH or spare parts approved by Stahl-Armaturen PERSTA GmbH.
- If you have any questions or if anything is unclear, always contact our customer service organisation (contact details on page 3).



Spare parts recommendation in the scope of delivery

The spare parts recommendation is included in the scope of delivery of the valve.

Pumping medium**WARNING!****Danger of injury due to pumping medium under pressure!**

In operating status, as well as in decommissioned status, depending on the version of the valve, injuries can occur due to medium escaping under high pressure.

- Do not unscrew threaded connections.
- If threaded connections are loose, inform the operating company and have the pipe section in question shut-off.
- If threaded connections are loose have the cause for this clarified and eliminated. If necessary have the manufacturer check the valve.

**WARNING!****Pumping medium is a health hazard!**

Contact with the pumping medium can have health implications.

- Handle pumping medium in accordance with the instructions in the manufacturer's safety data sheet.
- Wear protective equipment: Protective gloves, safety footwear, protective goggles, protective work clothing.
- Soak up escaped pumping medium without delay and dispose of it in an environmentally responsible manner.

Defective sealing elements**WARNING!****Danger of injury due to the use of previously used sealing elements!**

Previously used sealing elements can cause injuries due to escaping pumping medium.

After each dismantling of the stem

- depending on the version, use a new bottom ring,
- new chamber rings,
- new packing rings, and
- a new O-ring.

Damage of sealing surfaces and slide faces



NOTICE!

Damage of sealing surfaces and slide faces due to the metallic processing of sealing surfaces and slide faces!

The metallic processing of sealing surfaces and slide faces and valve parts can cause material damage and valve malfunction.

- Sealing surfaces and slide faces of gaskets must not be
 - scratched with a scraper,
 - processed with wire brushes.
- Sealing surfaces and slide faces must be
 - pulled off with emery cloth,
 - processed with suitable abrasive tools or
 - scraped off with plastic tools/wooden tools.

Increased wear



NOTICE!

Material damage due to excessive use as throttling valve!

Excessive use of the valve as a throttling valve can result in malfunction and material damage due to overstressing of the components.

- Only use the valve briefly as a throttling valve.
- In normal operation use the valve as an open/close valve.
- Have the maintenance and replacement intervals shortened by the operating company depending on the use of the valve.

8.2 Maintenance schedule

The maintenance tasks that are required for optimum and trouble-free valve operation are described in the sections below.

If regular inspections indicate increased wear, the required maintenance intervals must be reduced in accordance with the actual signs of wear. For questions concerning maintenance tasks and intervals, contact Stahl-Armaturen PERSTA GmbH Customer Service (contact details p. 3).

Interval	Maintenance work	Personnel
Depending on frequency of operation, operating and ambient conditions/ specified by the operating company	Check the valve visually for leaks (↗ Chapter 8.3.1 “Visually checking the valve” on page 71)	Trained person (operator)
	Lubricate the stem and bearing (↗ Chapter 8.3.2 “Lubricating moving parts (stem thread)” on page 72)	Trained person (operator)
Use as throttling valve: depending on frequency of operation, operating and ambient conditions/ specified by the operating company	Check the stem for increased wear (↗ Chapter 8.3.4 “Removing and checking the stem” on page 85)	Industrial mechanic (for valves within the normal pressure range)
Every six months	Operate valve (open/close, ↗ Chapter 7.2 “Operating the valve” on page 61)	Trained person (operator)
Depending on duration of use, operating and ambient conditions	Replace the gland packing (↗ Chapter 8.3.3 “Replace the gland packing” on page 73)	Industrial mechanic (for valves within the normal pressure range)

8.3 Maintenance tasks

8.3.1 Visually checking the valve

- Personnel: ■ Trained person (operator)
- Protective equipment: ■ Industrial hard hat
- Safety goggles
- Protective work clothing
- Protective gloves
- Safety footwear

1. ➤ Check the stuffing box area for leaks.
2. ➤ Check the pipe connection flanges for leaks.

8.3.2 Lubricating moving parts (stem thread)

- Personnel: ■ Trained person (operator)
- Protective equipment: ■ Industrial hard hat
 ■ Safety goggles
 ■ Protective work clothing
 ■ Protective gloves
 ■ Safety footwear

1. ▶ Protect the stuffing box area from the lubricant.

2. ▶



Comply with the instructions in the manufacturer's documentation for the electric actuator.

With electric actuator: Couple the handwheel.

3. ▶



Comply with the instructions in the manufacturer's documentation for the hydraulic/pneumatic actuator.

With pneumatic and hydraulic actuator: Operate the valve via the controller.

4. ▶ Open the valve completely.

5. ▶ Depending on the version:

- Grease the stem thread with a brush.
- Grease stem thread and bearing via lubricating nipple (Fig. 25/1).

6. ▶ Completely close valve.

7. ▶ Repeat step 4–6 several times.

8. ▶



Comply with the instructions in the manufacturer's documentation for the electric actuator.

With electric actuator: Uncouple the handwheel.

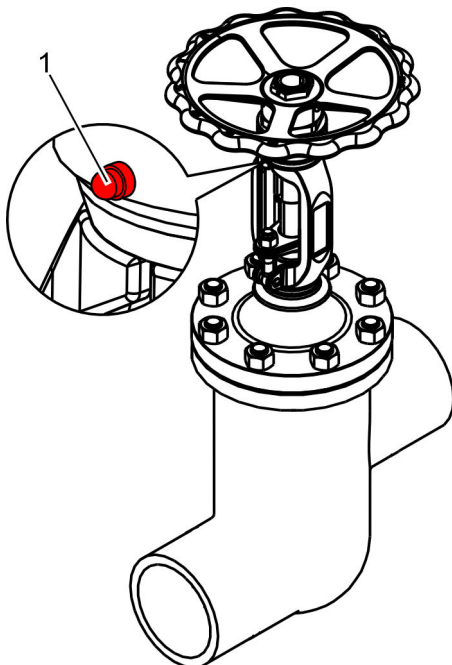

Fig. 25: Version with lubricating nipple

8.3.3 Replace the gland packing

Procedure with manual actuator (handwheel)

Replacement of the gland packing for a version of the valve with manual actuator (handwheel) is described below.

Personnel:	<ul style="list-style-type: none"> ■ Industrial mechanic (for valves within the normal pressure range) ■ Trained person (hoist)
Protective equipment:	<ul style="list-style-type: none"> ■ Industrial hard hat ■ Safety goggles ■ Protective work clothing ■ Protective gloves ■ Safety footwear
Special tool:	<ul style="list-style-type: none"> ■ Knock-out tool ■ Hoist ■ Sling gear ■ Spacers

Requirements:

- The valve must have cooled down/warmed up to ambient temperature.
- A depressurised state must have been established.
- The valve must have been moved into the middle position.

Removing the bonnet

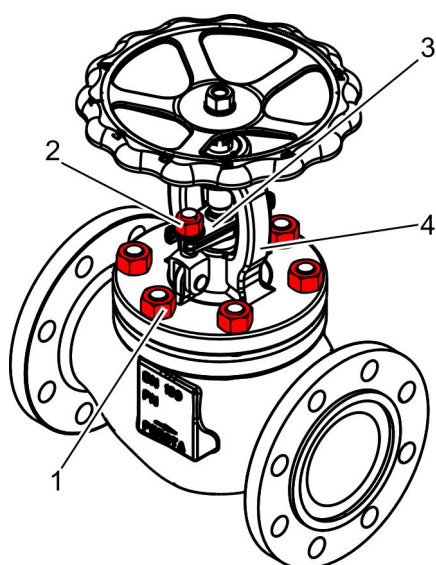

Fig. 26: Removing nuts

1. ➤ Attach bonnet to the hoist with suitable sling gear.
2. ➤ Use the hoist to safeguard the bonnet (Fig. 26/4) from falling off of the body.
3. ➤ Ensure that the bonnet (Fig. 26/4) and body cannot be lifted by the hoist.

4. ➤



WARNING!

Risk of injury due to pressurised valve!

Loosen and remove the nuts (Fig. 26/1) on the bonnet (Fig. 26/4).

5. ➤ Loosen and remove the nuts including washers (Fig. 26/2) on the gland follower flange (Fig. 26/3).

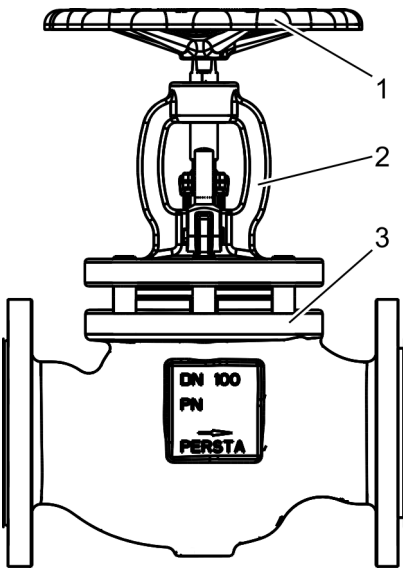

Fig. 27: Turning the handwheel

6. ▶ Turn the handwheel (Fig. 27/1) in the closing direction ("Shut").
 - ⇒ The bonnet (Fig. 27/2) is lifted off of the body (Fig. 27/3).
7. ▶ Position two spacers of the same height opposite each other between the body (Fig. 27/3) and the bonnet (Fig. 27/2).
8. ▶ Turn the handwheel (Fig. 27/1) in the opening direction ("Open").
 - ⇒ The bonnet (Fig. 27/2) is lowered onto the spacers.
9. ▶ Ensure that the bonnet (Fig. 27/2) rests on the spacers parallel to the body (Fig. 27/3).
10. ▶ Turn the handwheel (Fig. 27/1) in the opening direction.
 - ⇒ The gland packing is partially pulled out of the body.

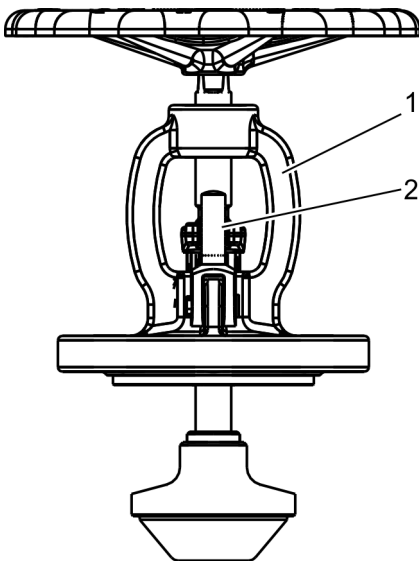
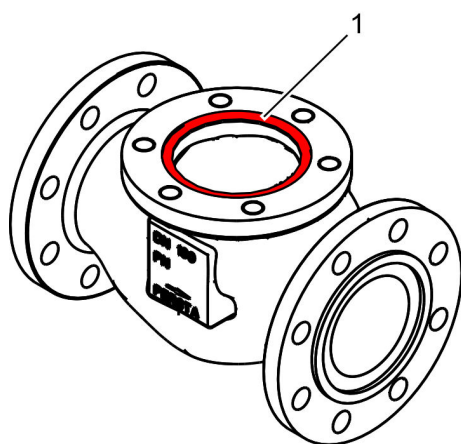

Fig. 28: Taking off the bonnet

11. ▶ Detach the complete bonnet (Fig. 28/1) including the stem (Fig. 28/2) and gland packing from the body with the hoist.
12. ▶ Remove the spacers from the body.
13. ▶ Ensure that no spacers have fallen into the body.

Replacing the cover gasket

- 14.** ➤ Remove the cover gasket (Fig. 29/1).
- 15.** ➤ Remove any residues from the groove in the body.
- 16.** ➤ Insert the new cover gasket (Fig. 29/1) in the groove on the body.

Fig. 29: Cover gasket

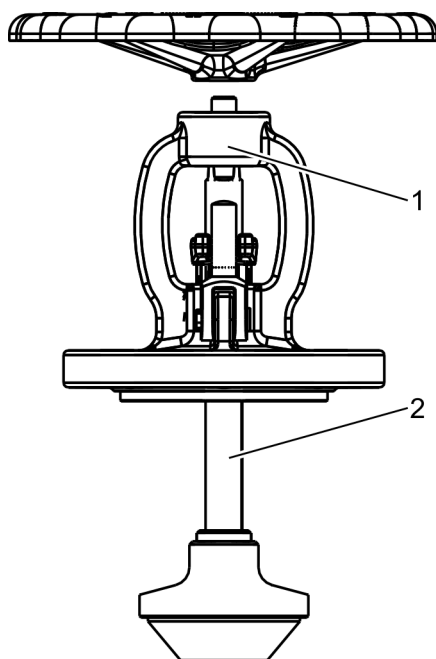
Removing the stem

- 17.** ➤ Unscrew the stem (Fig. 30/2) from the threaded bush.
- 18.** ➤ Remove the stem from the bonnet (Fig. 30/1).

Fig. 30: Unscrewing the stem

Removing the gland packing

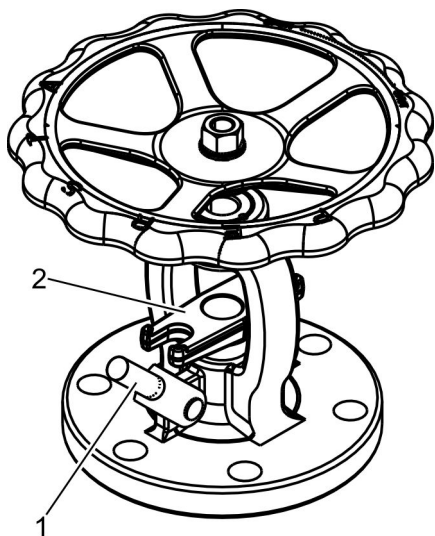

Fig. 31: Turning down the packing bolts

- 19. ▶ Turn down the packing bolts (Fig. 31/1).
- 20. ▶ Remove the gland follower flange (Fig. 31/2).

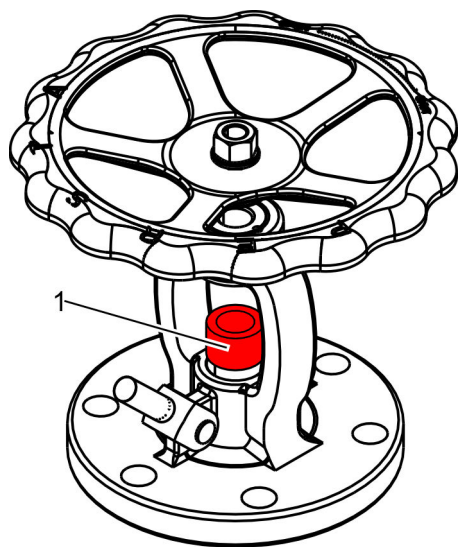

Fig. 32: Removing stuffing box elements

- 21. ▶ Use a packing extractor to remove the stuffing box elements (Fig. 32/1).

Cleaning the stem

- 22. ▶



NOTICE!

Risk of damage due to mechanical work on the contact surfaces!

Remove any residue from the packing elements on the stem.

Mounting the stem

Fig. 33: Screwing in the stem

Mounting the bonnet

- 23.▶ Insert the stem (Fig. 33/1) into the bonnet.
- 24.▶ Insert new stuffing box elements into the emptied and cleaned packing chamber.
- 25.▶ Attach the gland follower flange to the stem.

26.▶

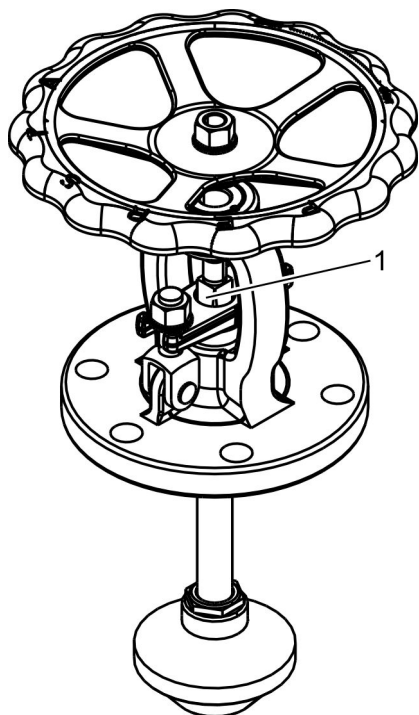
Gland follower flange tightened too firmly

Screw gland follower flange with washers loosely onto the packing bolts.

27.▶

Pay attention to the left-hand thread.

Screw the stem into the threaded bush on the handwheel.

- 28.▶ If there is an anti-twist device: Mount the anti-twist device in the stem.
- 29.▶ Move the shut-off element into the OPEN position.

30.▶ Fasten the bonnet to the hoist with suitable sling gear.

31.▶ Lift the bonnet above the body.

32.▶

NOTICE!
Risk of material damage due to careless lowering of the cone into the body!

Insert the stem into the body.

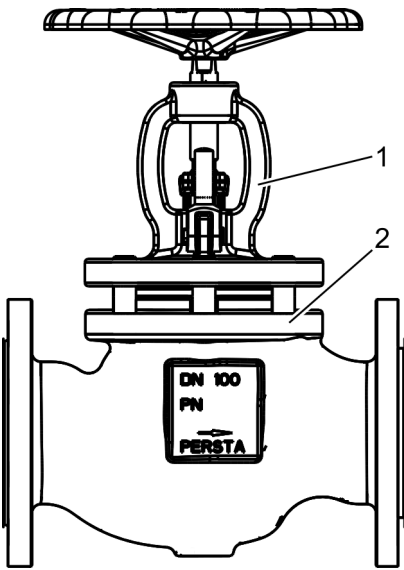

Fig. 34: Fitting the bonnet

33. Fit the bonnet (Fig. 34/1) onto the stud bolts on the body (Fig. 34/2).

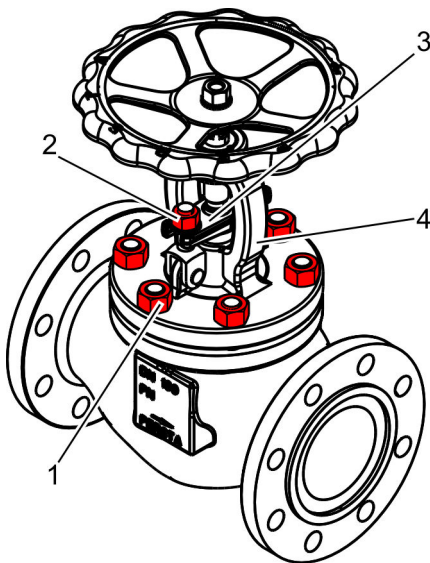

Fig. 35: Screwing on nuts

34. Loosely screw the nuts (Fig. 35/1) with the stud bolts into the body.

35.



WARNING!
Risk of injury due to incorrect tightening torques!

Tighten the nuts (Fig. 35/1) on the bonnet (Fig. 35/4) cross-wise as specified by the manufacturer.

36.



WARNING!
Risk of injury due to incorrect tightening torques!

Tighten the nuts (Fig. 35/2) on the gland follower flange (Fig. 35/3) as specified by the manufacturer.

Procedure for electric, pneumatic or hydraulic actuator

The procedure for an electric actuator is described below.



Comply with the instructions in the documentation provided by the manufacturer for mounting and removing the pneumatic or hydraulic actuator.



Use a hook wrench after removing the actuator

- To operate the stem, use a hook wrench instead of the handwheel that is provided with the manual actuator.
- Place the hook wrench on the flange of the threaded bush.

- | | |
|-----------------------|---|
| Personnel: | <ul style="list-style-type: none"> ■ Industrial mechanic (for valves within the normal pressure range) ■ Qualified electrician ■ Trained person (hoist) |
| Protective equipment: | <ul style="list-style-type: none"> ■ Industrial hard hat ■ Safety goggles ■ Protective work clothing ■ Protective gloves ■ Safety footwear |
| Special tool: | <ul style="list-style-type: none"> ■ Knock-out tool ■ Hoist ■ Sling gear ■ Hook wrench ■ Spacers |

Requirements:

- The valve must have cooled down/warmed up to ambient temperature.
- A depressurised state must have been established.
- The valve must have been moved into the middle position.
- The electrical system must be switched off and safeguarded against being switched on again.

1. ➔



See the manufacturer's documentation for the attachment points on the electric actuator.

Depending on the size and weight, have a second person or hoist with suitable sling gear hold the electric actuator in position.

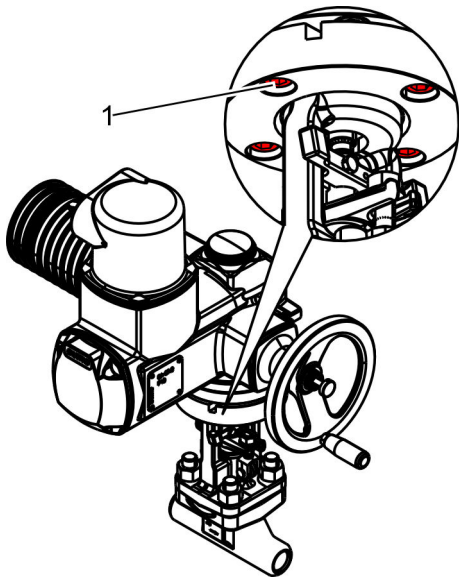

Fig. 36: Removing the bolts

2. ➤ Undo the bolts (Fig. 36/1) for the electric actuator and remove them along with the washers.
3. ➤ Take off the electric actuator and store it outside the work area.

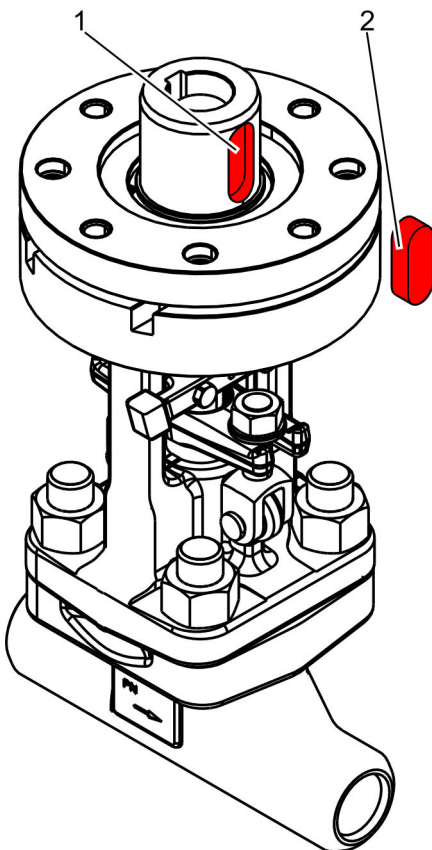

Fig. 37: Removing the feather key

4. ➤ Remove the feather key (Fig. 37/2) from the feather key groove (Fig. 37/1) of the threaded bush.

5. ➤



Use a hook wrench instead of the handwheel.

Carry out steps 1–36 ↗ “Procedure with manual actuator (handwheel)” on page 73.

Mounting the electric actuator

6. ➤ Insert the feather key into the feather key groove on the hub.

7. ➔



See the manufacturer's documentation for the attachment points on the electric actuator.

Have a second person or use a hoist and suitable sling gear to position the electric actuator above the flange on the bonnet.

8. ➔

Align the hub so that the feather key can be inserted into the receptacle on the electric actuator.

9. ➔



Ensure that the feather key is properly seated.

Lower the electric actuator onto the flange on the bonnet.

10. ➔

Fasten the electric actuator to the bonnet using bolts (Fig. 38/1) and washers.

11. ➔



WARNING!
Risk of injury due to incorrect tightening torques!

Tighten the bolts as specified by the manufacturer.

12. ➔

Establish the electrical connection as specified in the manufacturer's documentation for the electric actuator.

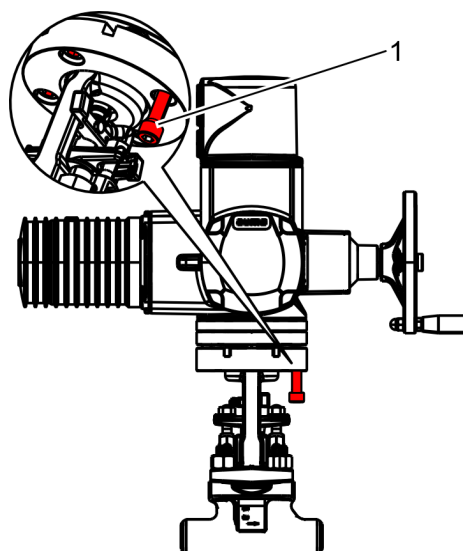

Fig. 38: Fastening the electric actuator

Procedure for shuttle valve



Options for replacing the stuffing box

With a shuttle valve, there are the following options for replacing the gland packing:

- Removal of the valve from the pipe and the stem through the lower flange.*
- Removal of the gland packing with valve installed, using slotted stuffing box elements (the stem remains installed).*

The replacement of the gland packing with valve installed as well as manual actuator (handwheel) is described below.

- Personnel:
- Industrial mechanic (for valves within the normal pressure range)
 - Trained person (hoist)
- Protective equipment:
- Industrial hard hat
 - Safety goggles
 - Protective work clothing
 - Protective gloves
 - Safety footwear
- Special tool:
- Knock-out tool
- Requirements:
- The valve must have cooled down/warmed up to ambient temperature.
 - A depressurised state must have been established.
 - For all other actuator types: The actuator must have been removed.
 - The valve must have been moved into the middle position.

Removing the shifting claw

Fig. 39: Undoing the threaded connections

1. ➔ If there is a shifting claw (Fig. 39/2): undo the nuts (Fig. 39/1) and remove them together with the washers.
2. ➔ Drive the anti-twist device (tension pin, Fig. 39/3) out of the shifting claw (Fig. 39/2) using the knock-out tool.
3. ➔ Remove the two-piece shifting claw (Fig. 39/2).

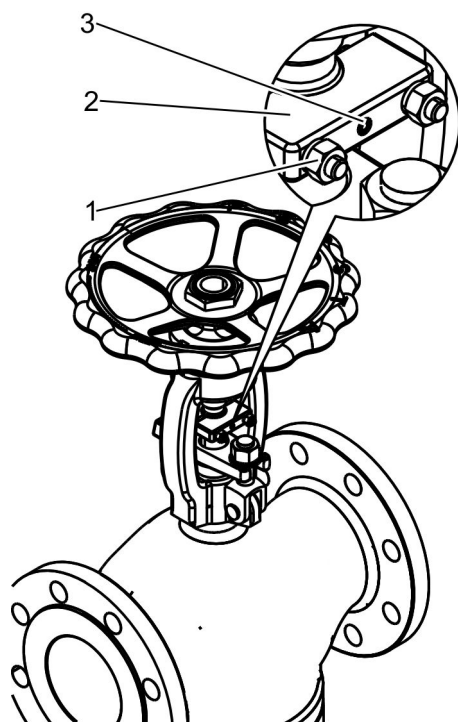
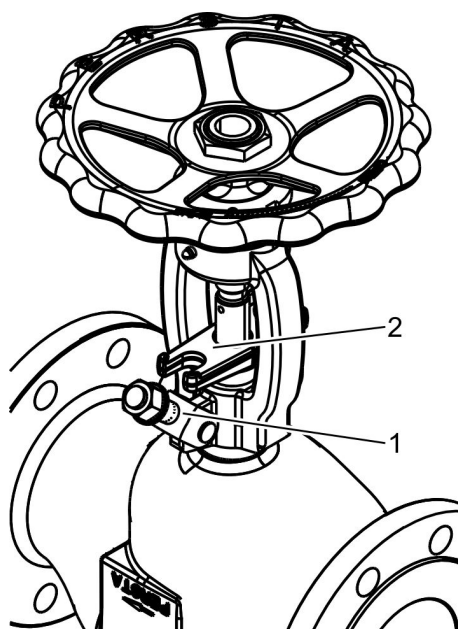

Fig. 40: Turning down the packing bolts

4. ➔ Undo the nuts on the gland follower flange (Fig. 40/2) until the eyebolts (Fig. 40/1) can be folded to the side.

Removing the gland packing

5. ➔ Push the gland follower flange (Fig. 40/2) up as far as possible.

Cleaning the stem

6. Use a packing extractor to remove the stuffing box elements.

7.



NOTICE!

Risk of damage due to mechanical work on the contact surfaces!

Remove any residue from the packing elements on the stem.

8.



WARNING!

Unsuitable stuffing box elements!

Insert new stuffing box elements procured from Stahl-Armaturen PERSTA GmbH into the emptied and cleaned packing chamber.

9. Push the gland follower flange down on to the stuffing box elements.

10.



Gland follower flange tightened too firmly

Bolt the gland follower flange loosely using the eyebolts.

11. If there is a shifting claw (Fig. 41/2): Fit the two-piece shifting claw (Fig. 41/2) from two sides on to the stem.

12. Make sure that the anti-twist device (tension pin, Fig. 41/3) can be mounted in the drilled hole of the stem and shifting claw (Fig. 41/detail).

13. Mount the anti-twist device (tension pin, Fig. 41/3).

14. Fasten the shifting claw (Fig. 41/2) with bolts (Fig. 41/1), washers and nuts (Fig. 41/4).

15.



WARNING!

Risk of injury due to incorrect tightening torques!

Tighten the nuts on the gland follower flange as specified by the manufacturer.

16. If present, mount the actuator as specified by the manufacturer and adjust the end positions.

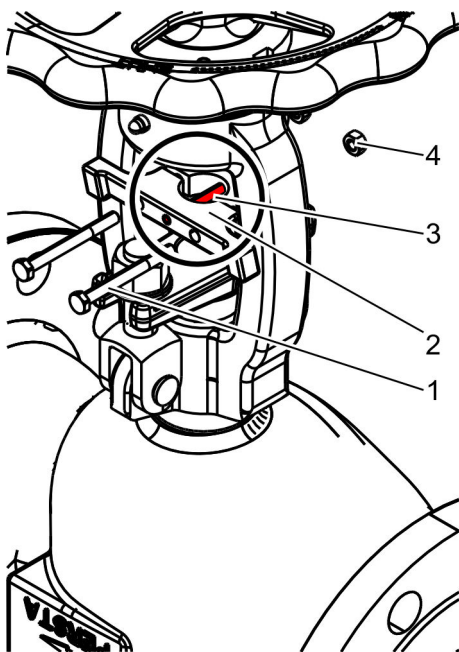

Fig. 41: Mounting the shifting claw

8.3.4 Removing and checking the stem

Procedure with manual actuator (handwheel)

Personnel:	<ul style="list-style-type: none">■ Industrial mechanic (for valves within the normal pressure range)■ Trained person (hoist)
Protective equipment:	<ul style="list-style-type: none">■ Industrial hard hat■ Safety goggles■ Protective work clothing■ Protective gloves■ Safety footwear
Special tool:	<ul style="list-style-type: none">■ Sling gear■ Hoist

1. ➤ Carry out work steps 1–18 of the maintenance task "Replacing the gland packing" (☞ *"Procedure with manual actuator (handwheel)" on page 73*).
2. ➤ Check the stem and cone for wear.
3. ➤ If necessary, replace the old stem with a new stem or have it machined by a specialised external company.
4. ➤ Carry out work steps 19–37 of the maintenance task "Replacing the gland packing" (☞ *"Procedure with manual actuator (handwheel)" on page 73*).

Procedure for electric, pneumatic or hydraulic actuator

Personnel:	<ul style="list-style-type: none"> ■ Industrial mechanic (for valves within the normal pressure range) ■ Trained person (hoist)
Protective equipment:	<ul style="list-style-type: none"> ■ Industrial hard hat ■ Safety goggles ■ Protective work clothing ■ Protective gloves ■ Safety footwear
Special tool:	<ul style="list-style-type: none"> ■ Sling gear ■ Hoist ■ Knock-out tool ■ Spacers ■ Hook wrench

1. → Carry out work steps 1–4 of the maintenance task "Replacing the gland packing" (☞ *"Procedure for electric, pneumatic or hydraulic actuator"* on page 79).

2. →



Use a hook wrench instead of the hand-wheel.

Carry out work steps 1–18 of the maintenance task "Replacing the gland packing" (☞ *"Procedure with manual actuator (handwheel)"* on page 73).

3. → Check the stem and cone for wear.

4. → If necessary, replace the old stem with a new stem or have it machined by a specialised external company.

5. → Carry out work steps 19–37 of the maintenance task "Replacing the gland packing" (☞ *"Procedure with manual actuator (handwheel)"* on page 73).

6. → Carry out work steps 6–12 of the maintenance task "Replacing the gland packing" (☞ *"Procedure for electric, pneumatic or hydraulic actuator"* on page 79).

8.4 After maintenance

After maintenance has been completed, carry out work for initial start-up (☞ *Chapter 6 "Initial start-up"* on page 53).

9 Faults and troubleshooting

9.1 Safety notices for fault correction

Electric shock

**DANGER!****Risk of fatal injury from electric shock!**

There is a risk of fatal injury when touching live components of the actuator. Switched-on electrical components can execute uncontrolled movements and can cause serious injuries.

- Prior to starting work, switch off the supply of electricity and definitively disconnect it.
- Only have an electrician perform tasks on electrical lines and components.

Safeguard against restart

**DANGER!****Life-threatening danger due to unintended restart!**

The unauthorised switch-on of the energy supply during work poses a danger of severe or fatal injuries for persons in the danger zone.

- Prior to beginning work, switch off all energy supplies and safeguard them from being switched on again.
- Safeguard the system area.

Improperly executed fault correction tasks



WARNING!

Danger of injury due to improper fault correction!

Improperly executed fault correction tasks can cause severe injury and significant material damage.

- For faults that require intervention, only correct them after you have ensured that
 - the system area in question is secured
 - the valve is depressurised
 - the valve has cooled-down/warmed-up to ambient temperature.
- If in doubt, obtain the assistance of experienced persons or contact Stahl-Armaturen PERSTA GmbH Customer Service.
- Comply with the following before restarting the system:
 - Ensure that all fault correction tasks have been properly executed and concluded in accordance with the instructions in this manual.
 - Ensure that nobody is in the danger zone.
 - Ensure that all covers and protective devices are installed correctly and that they function properly.

Thermal dangers



WARNING!

Danger of injury due to high/low temperatures!

Depending on the insert of the valve or of the pipe, injuries can occur due to the high or low temperature of the components.

- When working on components or activating final control equipment, wear protective equipment: Protective gloves, protective goggles.
- Prior to performing tasks on these components, allow them to cool down/warm up to ambient temperature.
- Have the protective insulation provided by the operating company attached.

Pumping medium



WARNING!

Danger of injury due to pumping medium under pressure!

In operating status, as well as in decommissioned status, depending on the version of the valve, injuries can occur due to medium escaping under high pressure.

- Do not unscrew threaded connections.
- If threaded connections are loose, inform the operating company and have the pipe section in question shut-off.
- If threaded connections are loose have the cause for this clarified and eliminated. If necessary have the manufacturer check the valve.



WARNING!

Pumping medium is a health hazard!

Contact with the pumping medium can have health implications.

- Handle pumping medium in accordance with the instructions in the manufacturer's safety data sheet.
- Wear protective equipment: Protective gloves, safety footwear, protective goggles, protective work clothing.
- Soak up escaped pumping medium without delay and dispose of it in an environmentally responsible manner.

Hazards associated with the pneumatic system



WARNING!

Danger of injury due to pneumatic energy!

Pneumatically-powered components of the valve, can cause severe injuries.

- Only have pneumatic specialists perform tasks on the pneumatic equipment.
- Prior to starting the tasks on the pneumatic equipment ensure that it is completely depressurised. Completely depressurise pressure accumulators.
- Wear personal protective equipment.

Fluid under high pressure



WARNING!

Danger of injury due to hydraulic energy!

Hydraulically-powered components of the valve, as well as the triggering of the overpressure valve can cause severe injuries.

- Only have specialised personnel perform tasks on the hydraulic system.
- Prior to starting the tasks on the hydraulic system ensure that it is completely depressurised. Completely depressurise pressure accumulators.
- Operate the valve in a frost-free environment to prevent the body from bursting.
- Wear personal protective equipment.

Behaviour if there are dangerous faults

The following always applies:

1. ➤ For faults that pose an imminent danger to personnel or material assets, immediately trigger the emergency stop function.
2. ➤ Determine the fault cause.
3. ➤ If correction of the fault requires work in the danger zone, secure the system area in question, and depressurise the valve.
4. ➤ Have faults that affect the safe operation of the valve corrected by the manufacturer.

9.2 Fault table

Fault description	Cause	Remedy	Personnel
Leakage of the shut-off device	Solid matter in the medium that has damaged the seat	Grind the seats, if necessary have damaged components replaced.	Industrial mechanic (for valves within the normal pressure range)

Fault description	Cause	Remedy	Personnel
Leakage of the shut-off device	Deformation of the seat surface due to an impermissibly high tension on the valve or due to thermal tension	Grind the seats, if necessary have damaged components replaced. Determine the cause of the deformation and have it rectified.	Industrial mechanic (for valves within the normal pressure range)
	Erosion or corrosion, e.g. due to the wrong selection of nominal valve width or valve material	Have the design of the valve checked.	Industrial mechanic (for valves within the normal pressure range)
	Shut-off element does not close tightly	Remove the stem (↪ <i>Chapter 8.3.4 "Removing and checking the stem" on page 85</i>) and have the cause of the malfunction determined and rectified by Stahl-Armaturen PERSTA GmbH customer service (contact details on page 3) or an external specialised company.	Industrial mechanic (for valves within the normal pressure range)
	Stem or cone is worn due to overlong use as throttling valve	Remove stem. Check the stem and cone for wear (↪ <i>Chapter 8.3.4 "Removing and checking the stem" on page 85</i>).	Industrial mechanic (for valves within the normal pressure range)
End position not reached	Actuator setting (with optional electric, pneumatic or hydraulic actuator) is incorrect	Set the actuator correctly.	Industrial mechanic (for valves within the normal pressure range)
	Valve bearing, stem thread, lift stop or inner parts of the valve are defective	Replace the damaged parts.	Industrial mechanic (for valves within the normal pressure range)
	Stuffing box has been overtightened	Tighten the stuffing box correctly, if necessary replace the gland packing (↪ <i>Chapter 8.3.3 "Replace the gland packing" on page 73</i>).	Industrial mechanic (for valves within the normal pressure range)
	Moving parts insufficiently lubricated	Lubricate the moving parts (↪ <i>Chapter 8.3.2 "Lubricating moving parts (stem thread)" on page 72</i>).	Trained person (operator)
Leakage of the stuffing box	Insufficient maintenance	Shut off the pipe section affected. Retighten the gland follower flange to the tightening torque specified by the manufacturer. If necessary, replace the stuffing box (↪ <i>Chapter 8.3.3 "Replace the gland packing" on page 73</i>).	Industrial mechanic (for valves within the normal pressure range)

Fault table

Fault description	Cause	Remedy	Personnel
Leakage of the stuffing box	Destruction of the stuffing box due to the use of a packing material without sufficient media or temperature resistance	Shut off the pipe section affected. Replace the stuffing box with a suitable packing set (↪ Chapter 8.3.3 "Replace the gland packing" on page 73).	Industrial mechanic (for valves within the normal pressure range)
	Wear of the packing material	Shut off the pipe section affected. Replace the stuffing box (↪ Chapter 8.3.3 "Replace the gland packing" on page 73).	Industrial mechanic (for valves within the normal pressure range)
Valve does not function (with optional electric, pneumatic or hydraulic actuator)	Electric actuator does not function	Check electric actuator as specified in the manufacturer's documentation.	Qualified electrician
	Hydraulic actuator does not function	Check hydraulic actuator as specified in the manufacturer's documentation.	Hydraulics Specialist
	Pneumatic actuator does not function	Check pneumatic actuator as specified in the manufacturer's documentation.	Pneumatics Specialist
Malfunction of the valve	End contacts (with optional electric, pneumatic or hydraulic actuator) are defective	Have the end contacts checked. Prior to readjustment, consult Stahl-Armaturen PERSTA GmbH customer service (contact details p. 3).	Qualified electrician
	Torque switch (with optional electric, pneumatic or hydraulic actuator) is defective	Have the torque switch checked. Prior to readjustment, consult Stahl-Armaturen PERSTA GmbH customer service (contact details p. 3).	Qualified electrician
	Limit switch (with optional electric, pneumatic or hydraulic actuator) is defective	Have the limit switch checked. Prior to readjustment, consult Stahl-Armaturen PERSTA GmbH customer service (contact details p. 3).	Qualified electrician
Jerky lifting movement	Gland packing is too tight	Readjust gland packing, replace if necessary (↪ Chapter 8.3.3 "Replace the gland packing" on page 73).	Industrial mechanic (for valves within the normal pressure range)

10 Removal, disposal

10.1 Safety notice for dismantling and disposal

Electric shock

**DANGER!****Risk of fatal injury from electric shock!**

There is a risk of fatal injury when touching live components of the actuator. Switched-on electrical components can execute uncontrolled movements and can cause serious injuries.

- Prior to starting work, switch off the supply of electricity and definitively disconnect it.
- Only have an electrician perform tasks on electrical lines and components.

Improper dismantling

**WARNING!****Danger of injury due to improper dismantling!**

Stored residual energy, sharp-edged components, points and corners on or in the valve, or on the required tools can cause serious injury.

- Prior to starting work ensure that there is adequate free space.
- Handle open, sharp-edged components carefully.
- Ensure order and cleanliness at the workstation! Loosely stacked components or components and tools that are lying about can cause accidents.
- Dismantle components properly. Pay attention to the high dead weight of some of the components. If necessary use hoists.
- Secure the components so that they do not fall down or fall over.
- If anything is unclear obtain the assistance of Stahl-Armaturen contact PERSTA GmbH customer service (contact details p. 3).

Heavy weight of the valve



WARNING!

Danger of injury due to the heavy weight of the valve!

The heavy weight of the valve, and of its components, can result in severe injuries.

- Transport valves with a suitable hoist or forklift.
- Don not lift valves via the handwheel.
- Do not lift valves via the actuator.
- If possible, lift valves via the bonnet.
- Use approved and functional sling gear.
- Safeguard valves and components from falling over.

Suspended loads



WARNING!

Danger of injury due to suspended loads!

Suspended loads can cause dangerous situations that can result in severe injuries.

- Do not step under suspended loads.
- Wear protective equipment: Industrial hard hat, safety footwear.
- Transport loads as close to the ground as possible.
- Only use approved sling gear and hoists.
- Ensure that hoist and sling gear have sufficient load-bearing capacity.

Fluid under high pressure



WARNING!

Danger of injury due to hydraulic energy!

Hydraulically-powered components of the valve, as well as the triggering of the overpressure valve can cause severe injuries.

- Only have specialised personnel perform tasks on the hydraulic system.
- Prior to starting the tasks on the hydraulic system ensure that it is completely depressurised. Completely depressurise pressure accumulators.
- Operate the valve in a frost-free environment to prevent the body from bursting.
- Wear personal protective equipment.

Hazards associated with the pneumatic system



WARNING!

Danger of injury due to pneumatic energy!

Pneumatically-powered components of the valve, can cause severe injuries.

- Only have pneumatic specialists perform tasks on the pneumatic equipment.
- Prior to starting the tasks on the pneumatic equipment ensure that it is completely depressurised. Completely depressurise pressure accumulators.
- Wear personal protective equipment.

Pumping medium



WARNING!

Danger of injury due to pumping medium under pressure!

In operating status, as well as in decommissioned status, depending on the version of the valve, injuries can occur due to medium escaping under high pressure.

- Do not unscrew threaded connections.
- If threaded connections are loose, inform the operating company and have the pipe section in question shut-off.
- If threaded connections are loose have the cause for this clarified and eliminated. If necessary have the manufacturer check the valve.



WARNING!

Pumping medium is a health hazard!

Contact with the pumping medium can have health implications.

- Handle pumping medium in accordance with the instructions in the manufacturer's safety data sheet.
- Wear protective equipment: Protective gloves, safety footwear, protective goggles, protective work clothing.
- Soak up escaped pumping medium without delay and dispose of it in an environmentally responsible manner.

10.2 Removal

- | | |
|-----------------------|--|
| Personnel: | <ul style="list-style-type: none"> ■ Industrial mechanic (for valves within the normal pressure range) ■ Forklift truck driver ■ Trained person (operator) ■ Trained person (hoist) ■ Disposal contractor |
| Protective equipment: | <ul style="list-style-type: none"> ■ Industrial hard hat ■ Safety goggles ■ Protective work clothing ■ Protective gloves ■ Safety footwear |
| Special tool: | <ul style="list-style-type: none"> ■ Hoist ■ Sling gear |

Requirements:

- The relevant pipe section is shut off.
 - Valve is in depressurised state.
 - Valve has been drained.
 - With electric actuator:
 - Power supply is switched off and physically disconnected.
 - With hydraulic or pneumatic actuator:
 - Ensure that the customer-provided hydraulic/pneumatic supply is switched off and safeguarded against being switched on again.
 - Hydraulic lines/pneumatic lines are in a depressurised state.
 - Hydraulic lines/pneumatic lines are removed from the actuator of the valve.
- 1.** ▶ Hold the valve in position with a suitable hoist (☞ *“Transporting individual valves” on page 42*).
 - 2.** ▶ Disconnect pipes on inlet side and outlet side from the valve.
 - 3.** ▶ Remove any supports, if necessary.
 - 4.** ▶ Use a suitable hoist to remove the valve from the pipe and set it down so that it is secured against falling over.
 - 5.** ▶ Clean the assemblies and components as required, and take them apart.

In doing so, comply with local occupational health and safety regulations.

10.3 Disposal

If a return or disposal agreement has not been concluded, then recycle dismantled components:

- Scrap metals.
- Recycle plastic elements.
- Sort and dispose of all other components according to material condition.



ENVIRONMENT!

Hazards for the environment due to improper disposal!

Hazards for the environment can occur due to improper disposal.

- Have electrical scrap and electronic components, hydraulic oil, lubricants and other auxiliary materials recycled or disposed of by approved specialist companies.
- If in doubt, contact the local authorities or specialist disposal companies for information regarding the environmentally responsible disposal.



Disposal

11 Technical data



See the scope of delivery of the valve for the technical data.

12 Index

A

Actuator	
Electric	33
Hydraulic	33
Manual	32
Pneumatic	33
Angle pattern valve	35
Anti-twist device	38

B

Behaviour in the event of an emergency	62
Bellows	31
Body shape	35
Brief description	7
Butt-weld valve	38

C

Connecting a hydraulic actuator	49
Connecting a pneumatic actuator	49
Connecting an electric actuator	48
Connection	38

D

Dimensions	99
Disposal	97

E

Electric actuator	33
Operating in an emergency	62
Remove	79
Electrical connection	38
Emergency	62
Emergency situation	22
Environmental protection	28

F

Fault table	90
Flanged valve	38
Flow direction arrow	15
Freezing temperatures can shatter pipes	20, 53

G

Gland packing	30, 31
---------------	--------

H

Handwheel	32, 61
Heating times / cooling times	57
Hinged eyebolts	31
Hydraulic actuator	
Remove	79
Hydraulic connection	38
Hydrostatic pressure test	51

I

Initial start-up	
Carrying out	57
Preparation	56
Installing the valve	47
Instruction	25
Insulating the valve	52
Intended use	13

L

Leak test	51
Leakages	90
Leaks	73, 79, 82
Shut-off device	90
Stuffing box	90
Limit switch	16, 38

M

Maintenance schedule	70
Malfunctions	90
Marking on handwheel	16
Markings	14
Misuse	13

O

Operating company	22
Operating principle	29
Order numbers	27

Ordering spare parts	27	Spare parts	27, 68
Overview	7	Special connection valve	38
P		Stem	
Packing bolts	31	Check	85
Painting the valve	51	Lubricate	72
Personal protective equipment	26	Remove	85
Personnel	23	Storage	43
Pickling	51	Storing the valve	43
Pickling medium	51	Symbols	
Pickling the valve	51	in the manual	11
Pneumatic actuator		On the valve	15
Remove	79	System pressure test	51
Pneumatic connection	39	T	
Position indicator	15, 38	T-pattern	34
Preparing for installation	47	Technical data	99
Principle	7	Throttling valve cone	32
Protective equipment	26	Tightening torque	99
R		Tools	9
Rating plate	14	Torque switch	16
Removal	96	Transporting a pallet	42
Replace the gland packing	73	U	
Replacing the gland packing	79, 82	Use	13
Residual risks	17	V	
S		Valve	
Safety signs	14	Operating	61
Seal	30, 31	transport	42
Sectional view	7	Visually checking the valve	71
Shifting claw	38	W	
Shut-off element	32	Weights	99
Shuttle valve	36, 82	Z	
Signs	14	Z shape	37
Slotted stuffing box elements	82		
Socket weld valve	38		